



2016
Product Guide

CONTENTS

ROTORS

MiniPro™	2-3
RPS® 50	4-5
RPS® 75	6-7
RPS® 75i	8-9
RPS® Select	10-11
ProPlus™	12-13
SuperPro™	14-15
ProSport™	16-17

SPRAYS

Pro-S™	18-19
NP Sprays	20
K-Sprays	21

NOZZLES

Rotary Nozzle Series	22-23
High Efficiency KVF Nozzles	24-25
KV Nozzles	26-27
Fixed Nozzles	28-29
Tree Bubblers	30
PC Dripline System	31

ELECTRIC VALVES

ProSeries 100 Valves	32-33
ProSeries 150 Valves	34-36
ProSeries 200 Valves	37

IRRIGATION CONTROLLERS

Pro Ex 2.0	38-39
RPS® 624	40
RPS® 469	41
RPS® 46	42
BL-KR	43

SINGLE STATION CONTROLLER

Single Station Controller	44
---------------------------	----

PUMP START RELAY

Pump Start Relay	45
------------------	----

INDEXING VALVES

4000 Series Indexing Valve	46
6000 Series Indexing Valve	47

RECLAIMED WATER (RCW)

RCW Series	48-49
Accessories	50-51
Charts	53-63
Warranty	64



Letter from the founder

K-Rain® is one of the world's leading manufacturers of gear-driven rotors, sprays, controllers and valves for the commercial and residential irrigation markets. With more than 100 patents and over 40 years of industry experience, our advanced design and engineering have made K-Rain products the easiest to install, set and use. We back our products with the strongest warranty program in the business – providing our distributors and contractors with confidence when installing K-Rain products. Our experienced customer service team, from the corporate office to our field representatives around the world, support our customers in a manner second to none in the industry.

During the last 10 years we have continued to make significant advances in developing products which critically enhance the efficient use of water. Our commitment to the environment extends not only to our products in the field but also encompasses our manufacturing processes. We promote the recycling of materials back into the marketplace or nature and continually evaluate our manufacturing processes to decrease our impact on the environment.

K-Rain began with a vision. Founder Carl Kah began with designing an automatic irrigation control system for his own home. This is the foundation of K-Rain. Today over 300 men and women make up the K-Rain team, serving customers in the United States and in more than 60 countries worldwide.

Beyond any technical advancement, these people are at the heart of all we do. We are proud to say “We love what we do. Everyday we go to work with one thought: Make it better.”

– Carl Kah, Founder



MINIPRO™

Application: Residential / Light Commercial

RADIUS: 18' – 36'

FLOW: .8 – 3.3 GPM

INLET: 1/2"

When considering the industry leading MiniPro™ gear driven rotor, think water efficiency. Now available in three popular heights and compatible with a wide selection of nozzles, the MiniPro™ brings flexibility to system design.



Features and Benefits

- **Revolutionary Patented Top Arc Set** – Simplified arc set allows for wet or dry adjustment in seconds.
- **1/2" Inlet** – Replaces all standard mini rotors and pop-up sprays.
- **Adjustable to 360°** – Provides a full range of adjustment from 40° to 360°.
- **Patented Top Arc Set Degree Markings** – Clearly indicates the current watering pattern and simplifies arc set adjustment.
- **Time Proven Patented Reversing Mechanism** – Assures continuous reverse and return...over a 35 year history.
- **Ratcheting Riser** – Allows for easy adjustment of your left starting position with a simple turn of the riser.
- **Rubber Cover** – Seals out dirt and increases product durability.
- **Wide Selection of Nozzles** – Provides flexibility in system design.
- **Optional Check Valve** – Prevents low head drainage.
- **Five Year Limited Warranty.**

Specifications

- Inlet: 1/2" Threaded NPT
- Arc Adjustment Range: 40° – 360°
- Flow Range: .8 – 3.3 GPM
- Pressure Rating: 20 – 70 PSI
- Precipitation Rate: .26 – .60 Inches Per Hour (Depending on Spacing and Nozzle Used)
- Overall Height (Popped Down): 4", 6", 12"
- Recommended Spacing: 17' – 34'
- Radius: 18' – 36'
- Nozzle Trajectory: 26°
- Riser Height: 4", 6" or 12"

Easy Arc Setting

Arc Selection 40° to 360°
Adjust From Left Start



Models

- 13003 MiniPro™ – 4"
- 13006 MiniPro™ – 6"
- 13012 MiniPro™ – 12"

OTHER OPTIONS: ADD TO PART NUMBER

- CV Check Valve
- NN No Nozzle
- RCW Reclaimed Water Use

How to Specify

Model Number	Description
13003	-RCW



Performance Data

NOZZLE	PRESSURE			RADIUS		FLOW RATE			PRECIP in/hr		PRECIP mm/hr	
	PSI	kPa	Bars	Ft.	M.	GPM	L/M	M ³ /H	■	▲	■	▲
#0.75	30	207	2.07	17'	5.1	0.8	2.8	0.2	.50	.58	21	24
	40	276	2.76	17'	5.1	0.8	3.0	0.2	.53	.62	22	26
	50	345	3.45	18'	5.4	0.9	3.4	0.2	.53	.62	23	26
#1.0	30	207	2.07	20'	6.0	0.9	3.4	0.2	.43	.50	18	21
	40	276	2.76	21'	6.3	1.2	4.5	0.3	.52	.60	22	25
	50	345	3.45	21'	6.3	1.3	4.9	0.3	.57	.66	24	28
#2.0	30	207	2.07	23'	6.9	1.4	5.3	0.4	.51	.59	21	25
	40	276	2.76	24'	7.2	1.7	6.4	0.4	.57	.66	24	28
	50	345	3.45	24'	7.2	1.9	7.2	0.5	.63	.73	27	31
#2.5 Pre-installed	30	207	2.07	25'	7.5	1.8	6.8	0.5	.55	.64	23	27
	40	276	2.76	27'	8.1	2.1	8.0	0.5	.55	.64	23	27
	50	345	3.45	27'	8.1	2.4	9.1	0.6	.63	.73	27	31
#3.0	30	207	2.07	28'	8.4	2.7	10.2	0.7	.66	.77	28	32
	40	276	2.76	30'	9.0	3.0	11.4	0.8	.64	.74	27	31
	50	345	3.45	30'	9.0	3.3	12.5	0.8	.71	.82	30	34

*All precipitation rates calculated for 180° operation. For the precipitation rate for a 360° sprinkler, divide by 2.



Perfect for small lawn and landscape areas
and for replacing fixed spray zones.

RPS® 50

Application: Residential / Light Commercial

RADIUS: 18' – 36'

FLOW: .8 – 3.3 GPM

INLET: 1/2"

The RPS® 50 is a gear-driven, rotary sprinkler, capable of covering an area of 18' to 36' (5.5 to 10.1 M) radius at nozzle pressure of 30 to 50 PSI (2.1 to 3.4 bar) with a discharge rate of .8 to 3.3 GPM (2.8 to 12.5 LPM).

The RPS® 50 is supplied with five (5) numerically coded interchangeable nozzles. Sprinkler nozzle trajectory is 26°. The sprinkler has a stainless steel radius adjustment screw and has arc adjustment from 40° to 360°.



Features and Benefits

- **Right Position Start** – Rotor rotates counterclockwise from fixed right start position.
- **Time Proven Patented Reversing Mechanism** – Assures continuous reverse and return...over a 35 year history.
- **Ratcheting Riser** – Allows for easy adjustment of your right starting position with a simple turn of the riser.
- **Rubber Cover** – Seals out dirt and increases product durability.
- **Wide Selection of Nozzles** – Provides flexibility in system design.
- **Optional Check Valve** – Prevents low head drainage.

Specifications

- Inlet: 1/2" Threaded NPT
- Arc Adjustment Range: 40° – 360°
- Flow Range: .8 – 3.3 GPM
- Pressure Rating: 20 – 70 PSI
- Precipitation Rate: .26 – .60 Inches Per Hour (depending on spacing and nozzle used)
- Overall Height (Popped Down): 6"
- Recommended Spacing: 17' – 34'
- Radius: 18' – 36'
- Nozzle Trajectory: 26°
- Riser Height: 4"

Easy Arc Setting

Arc Selection 40° to 360°
Adjust From Right Start



How to Specify

Model Number	Description
RPS50	-CV

Models

RPS50 RPS® 50 Rotor

OTHER OPTIONS: ADD TO PART NUMBER

-CV Check Valve
-NN No Nozzle
-RCW Reclaimed Water Use



Designed for smaller areas, the RPS® 50 is available with a wide selection of nozzles that bring flexibility to system design.

Performance Data

NOZZLE	PRESSURE			RADIUS		FLOW RATE			PRECIP in/hr		PRECIP mm/hr	
	PSI	kPa	Bars	Ft.	M.	GPM	L/M	M ³ /H	■	▲	■	▲
#0.75	30	207	2.07	17'	5.1	0.8	2.8	0.2	.50	.58	21	24
	40	276	2.76	17'	5.1	0.8	3.0	0.2	.53	.62	22	26
	50	345	3.45	18'	5.4	0.9	3.4	0.2	.53	.62	23	26
#1.0	30	207	2.07	20'	6.0	0.9	3.4	0.2	.43	.50	18	21
	40	276	2.76	21'	6.3	1.2	4.5	0.3	.52	.60	22	25
	50	345	3.45	21'	6.3	1.3	4.9	0.3	.57	.66	24	28
#2.0	30	207	2.07	23'	6.9	1.4	5.3	0.4	.51	.59	21	25
	40	276	2.76	24'	7.2	1.7	6.4	0.4	.57	.66	24	28
	50	345	3.45	24'	7.2	1.9	7.2	0.5	.63	.73	27	31
#2.5 Pre-installed	30	207	2.07	25'	7.5	1.8	6.8	0.5	.55	.64	23	27
	40	276	2.76	27'	8.1	2.1	8.0	0.5	.55	.64	23	27
	50	345	3.45	27'	8.1	2.4	9.1	0.6	.63	.73	27	31
#3.0	30	207	2.07	28'	8.4	2.7	10.2	0.7	.66	.77	28	32
	40	276	2.76	30'	9.0	3.0	11.4	0.8	.64	.74	27	31
	50	345	3.45	30'	9.0	3.3	12.5	0.8	.71	.82	30	34

*All precipitation rates calculated for 180° operation. For the precipitation rate for a 360° sprinkler, divide by 2.



RPS® 75

Application: Residential / Light Commercial

RADIUS: 22' – 51'

FLOW: .75 – 8.3 GPM

INLET: 3/4"

The RPS® 75 is a direct replacement for Hunter® PGP® rotors. The reversing mechanism, a K-Rain patented feature, ensures continuous reverse and return.

With K-Rain's wide selection of standard and low angle nozzles, the RPS® 75 provides even water distribution.



Features and Benefits

- **Direct Replacement for Hunter® PGP®.**
- **Right Position Start** – Rotor rotates counterclockwise from fixed right start position.
- **Riser Fits in Existing Hunter® PGP® cans** – Simply unscrew the existing riser from the PGP® can and replace with the RPS® 75 riser.
- **Top Adjustment** – No training necessary – the RPS® 75 has the same adjustment procedure as the Hunter® PGP®.
- **Full and Part Circle Rotation** – Provides a full range of adjustment from 40° to 360°.
- **Non-flushing Wiper Seal** – Reduces leaks caused by debris trapped under seal.
- **3/4" Inlet** – Replaces all standard rotors.
- **Ideal for Low Flow Applications.**
- **Universal Adjustment Tool** – Compatible with existing Hunter® products.
- **Rubber Cover** – Seals out dirt and increases durability.
- **Wide Selection of Nozzles** – Including standard and low angle, provides flexibility in system design.
- **Five Year Limited Warranty.**

Easy Arc Setting

Arc Selection 40° to 360°

Adjust From Right Start



Models

RPS75 RPS® 75 Rotor

OTHER OPTIONS: ADD TO PART NUMBER

-CV Check Valve
-NN No Nozzle
-RCW Reclaimed Water Use

Specifications

- Inlet: 3/4" Threaded NPT
- Arc Adjustment Range: 40° – 360°
- Flow Range: .75 – 8.2 GPM
- Pressure Rating: 30 – 70 PSI
- Precipitation Rate: .16 – .99 Inches Per Hour (Depending on Spacing and Nozzle Used)
- Overall Height (Popped Down): 7 3/8"
- Recommended Spacing: 25' – 45'
- Radius: 22' – 51'
- Nozzle Trajectory: 25°
- Low Angle Nozzle Trajectory: 11°
- 8 Standard and 4 Low Angle Nozzles Included
- Riser Height: 4"

How to Specify

Model Number
RPS75

Description
-RCW



Performance Data

NOZZLE	PRESSURE			RADIUS		FLOW RATE			PRECIP in/hr		PRECIP mm/hr	
	PSI	kPa	Bars	Ft.	M.	GPM	L/M	M ³ /H	■	▲	■	▲
#0.75	30	206	2.1	29'	8.8	0.7	2.6	0.16	0.16	0.19	6.46	7.46
	40	275	2.8	30'	9.1	0.8	3.0	0.18	0.17	0.20	6.97	8.05
	50	344	3.4	30'	9.1	0.9	3.4	0.20	0.19	0.22	7.90	9.13
	60	413	4.1	31'	9.4	1.0	3.8	0.23	0.20	0.23	8.28	9.58
#1.0	30	206	2.1	30'	9.1	0.9	3.4	0.20	0.19	0.22	7.90	9.13
	40	275	2.8	31'	9.4	1.0	3.8	0.23	0.20	0.23	8.28	9.56
	50	344	3.4	31'	9.4	1.2	4.5	0.27	0.24	0.28	9.80	11.32
	60	413	4.1	32'	9.8	1.3	4.9	0.30	0.24	0.28	9.82	11.34
#1.5	30	206	2.1	32'	9.8	1.2	4.5	0.27	0.23	0.26	9.02	10.42
	40	275	2.8	33'	10.1	1.4	5.3	0.32	0.25	0.29	10.00	11.00
	50	344	3.4	34'	10.4	1.6	6.1	0.36	0.27	0.31	10.86	12.54
	60	413	4.1	34'	10.4	1.8	6.8	0.41	0.30	0.35	12.10	13.98
#2.0	30	206	2.1	34'	10.4	1.6	6.1	0.36	0.27	0.31	10.86	12.54
	40	275	2.8	36'	11.0	1.8	6.8	0.41	0.27	0.31	10.82	12.49
	50	344	3.4	38'	11.6	2.0	7.6	0.45	0.27	0.31	10.87	12.55
	60	413	4.1	38'	11.6	2.2	8.3	0.50	0.29	0.34	11.87	13.71
#3.0 Pre-installed	30	206	2.1	36'	11.0	2.0	7.6	0.45	0.30	0.34	12.09	13.96
	40	275	2.8	38'	11.6	2.4	9.1	0.55	0.32	0.37	13.02	15.03
	50	344	3.4	40'	12.2	2.7	10.2	0.61	0.32	0.38	13.19	15.23
	60	413	4.1	40'	12.2	2.9	11.0	0.66	0.35	0.40	14.23	16.43
#4.0	30	206	2.1	36'	11.0	2.6	9.8	0.59	0.39	0.45	15.59	18.00
	40	275	2.8	40'	12.2	3.0	11.4	0.68	0.36	0.42	14.74	17.03
	50	344	3.4	42'	12.8	3.4	12.9	0.77	0.37	0.43	15.16	17.50
	60	413	4.1	42'	12.8	3.7	14.0	0.84	0.40	0.47	16.45	18.99
#6.0	40	275	2.8	38'	11.6	4.2	15.9	0.91	0.56	0.65	22.75	26.27
	50	344	3.4	43'	13.1	4.9	18.5	1.11	0.51	0.59	20.75	23.96
	60	413	4.1	46'	14.0	5.5	20.8	1.25	0.50	0.58	20.43	23.59
	70	482	4.8	47'	14.3	6.0	22.7	1.36	0.52	0.60	21.37	24.68
#8.0	40	275	2.8	45'	13.7	6.0	22.7	1.36	0.57	0.66	23.28	26.88
	50	344	3.4	48'	14.6	6.8	25.7	1.54	0.57	0.66	23.21	26.80
	60	413	4.1	49'	14.9	7.6	28.8	1.73	0.61	0.70	24.97	28.84
	70	482	4.8	51'	15.5	8.2	31.0	1.86	0.61	0.70	24.84	28.86



Low Angle Performance Data

NOZZLE	PRESSURE			RADIUS		FLOW RATE			PRECIP in/hr		PRECIP mm/hr	
	PSI	kPa	Bars	Ft.	M.	GPM	L/M	M ³ /H	■	▲	■	▲
#1.0	30	207	2.0	22'	6.7	1.2	4.5	.34	0.48	0.55	19.30	22.28
	40	275	3.0	24'	7.3	1.7	6.4	.39	0.57	0.66	23.12	26.70
	50	344	3.5	26'	7.9	1.8	6.8	.41	0.51	0.59	20.97	24.22
	60	413	4.0	28'	8.5	2.0	7.6	.46	0.49	0.57	20.25	23.38
#2.0	30	207	2.0	29'	8.8	3.0	11.4	.68	0.69	0.79	28.34	32.72
	40	275	3.0	32'	9.8	3.1	11.7	.71	0.58	0.67	23.45	27.08
	50	344	3.5	35'	10.7	3.5	13.2	.80	0.55	0.64	22.19	25.63
	60	413	4.0	37'	11.3	3.8	14.4	.87	0.53	0.62	21.71	25.07
#4.0	30	207	2.0	31'	9.4	3.4	12.9	.78	0.68	0.79	28.10	32.45
	40	275	3.0	34'	10.4	3.9	14.8	.89	0.65	0.75	26.34	30.42
	50	344	3.5	37'	11.3	4.4	16.7	1.00	0.62	0.71	25.18	29.07
	60	413	4.0	38'	11.6	4.7	17.8	1.07	0.63	0.72	25.46	29.40
#6.0	40	275	3.0	38'	11.6	6.5	24.6	1.68	0.87	1.00	35.19	40.64
	50	344	3.5	40'	12.2	7.3	27.6	1.66	0.88	1.01	35.70	41.22
	60	413	4.0	42'	12.8	8.0	30.3	1.82	0.87	1.01	35.60	41.11
	70	482	5.0	44'	13.4	8.3	32.6	1.96	0.86	0.99	34.95	40.36

*All precipitation rates calculated for 180° operation. For the precipitation rate for a 360° sprinkler, divide by 2.



A wide selection of nozzles, including standard and low angle, provides flexibility in system design.

RPS® 75i

Application: Residential / Light Commercial

RADIUS: 11' – 51'
FLOW: .35 – 8.6 GPM
INLET: 3/4"



RPS® 75i with Intelligent Flow Technology®

This new addition to K-Rain's line of rotors retains all of the features and benefits of the RPS® 75 and delivers even more! To reduce the radius and distance in other rotors on the market, the nozzle must be changed or the break-up screw must be engaged. These steps limit the maximum reduction to 25% and cause uneven watering. With the RPS® 75i, a simple turn of the patented Flow Control regulates distance and water flow proportionately—up to 50%.

The RPS® 75i delivers even water distribution, eliminates dry spots and provides better zone performance while saving water. All this in one rotor—the right rotor for every landscape!



Features and Benefits

- Reduce Distance and Flow Rate Proportionately
- Save Time on Every Project — New or retrofit
- Rugged RPS Family Construction
- Conserves Water
- Superior Uniformity
- Fewer Zones Required
- Improved Hydraulics

Specifications

- Inlet: 3/4" Threaded NPT
- Arc Adjustment Range: 40° – 360°
- Flow Range: .35 – 8.6 GPM
- Pressure Rating: 30 – 70 PSI
- Precipitation Rate: .124 – 2.0 in./hr.
- Overall Height (Popped Down): 7 3/8"
- Recommended Spacing: 25' – 45'
- Radius: 11' – 51'
- Nozzle Trajectory: 25°
- Low Angle Nozzle Trajectory: 11°
- Nozzles Included: 8 Standard, 4 Low Angle
- Riser Height: 4"

Easy Arc Setting

Arc Selection 40° to 360°
Adjust From Right Start



Models

RPS 75i RPS® 3/4" Rotor

OTHER OPTIONS: ADD TO PART NUMBER

- SS Stainless Steel
- CV Check Valve
- NN No Nozzle
- RCW Reclaimed Water Use

How to Specify

Model Number	Description
RPS 75i	-NN

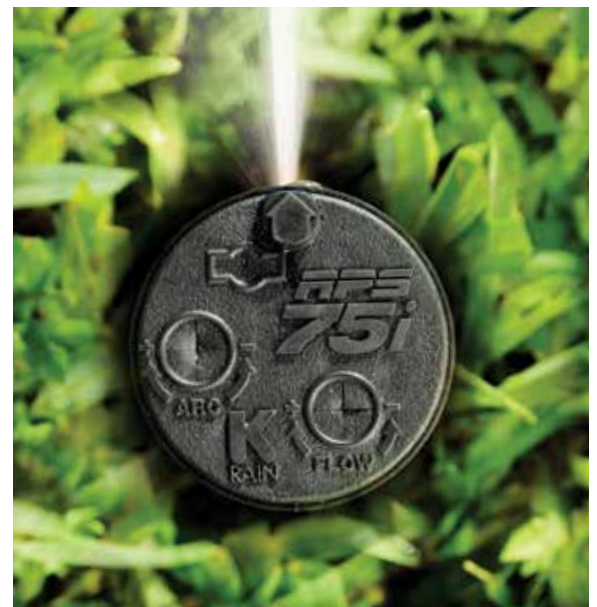

Performance Data

NOZZLE	PRESSURE PSI kPa Bar		NO ADJUSTMENT								-25% ADJUSTMENT								-50% ADJUSTMENT								
			RADIUS		FLOW		PRECIP in/hr mm/hr				RADIUS		FLOW		PRECIP in/hr mm/hr				RADIUS		FLOW		PRECIP in/hr mm/hr				
			Ft.	M.	GPM	L/M	■	▲	■	▲	Ft.	M.	GPM	L/M	■	▲	■	▲	Ft.	M.	GPM	L/M	■	▲	■	▲	
#0.75	30	207	2.1	33'	10.1	0.7	2.7	.12	.14	3	4	25'	8	0.5	2.0	.16	.19	4	5	17	5	0.4	1.3	.25	.29	6	7
	40	276	2.8	33'	10.1	0.8	3.0	.14	.16	4	4	25'	8	0.6	2.3	.19	.22	5	6	17	5	0.4	1.5	.28	.33	7	8
	50	345	3.4	35'	10.7	0.9	3.5	.15	.17	4	4	26'	8	0.7	2.6	.19	.22	5	6	18	5	0.5	1.7	.29	.33	7	9
	60	414	4.1	36'	11.0	1.0	3.8	.15	.17	4	4	27'	8	0.8	2.8	.20	.23	5	6	18	5	0.5	1.9	.30	.34	8	9
#1.0	30	207	2.1	35'	10.7	1.1	4.2	.17	.20	4	5	26'	8	0.8	3.1	.23	.27	6	7	18	5	0.6	2.1	.35	.40	9	10
	40	276	2.8	37'	11.3	1.3	4.9	.18	.21	5	5	28'	8	1.0	3.7	.24	.28	6	7	19	6	0.7	2.5	.37	.42	9	11
	50	345	3.4	37'	11.3	1.5	5.5	.20	.24	5	6	28'	8	1.1	4.1	.27	.31	7	8	19	6	0.7	2.8	.41	.47	10	12
	60	414	4.1	38'	11.6	1.6	6.1	.21	.25	5	6	29'	9	1.2	4.5	.28	.33	7	8	19	6	0.8	3.0	.43	.49	11	13
#1.5	30	207	2.1	37'	11.3	1.4	5.1	.19	.22	5	6	28'	8	1.0	3.8	.25	.29	6	7	19	6	0.7	2.6	.38	.44	10	11
	40	276	2.8	39'	11.9	1.6	6.1	.20	.23	5	6	29'	9	1.2	4.5	.27	.31	7	8	20	6	0.8	3.0	.41	.47	10	12
	50	345	3.4	40'	12.2	1.9	7.0	.22	.26	6	7	30'	9	1.4	5.3	.30	.34	8	9	20	6	0.9	3.5	.45	.51	11	13
	60	414	4.1	41'	12.5	2.0	7.6	.23	.26	6	7	31'	9	1.5	5.7	.31	.35	8	9	21	6	1.0	3.8	.46	.53	12	13
#2.0	30	207	2.1	36'	11.0	1.7	6.3	.25	.28	6	7	27'	8	1.3	4.7	.33	.38	8	10	18	5	0.8	3.1	.49	.57	13	14
	40	276	2.8	38'	11.6	2.0	7.4	.26	.30	7	8	29'	9	1.5	5.5	.35	.40	9	10	19	6	1.0	3.7	.52	.60	13	15
	50	345	3.4	39'	11.9	2.2	8.2	.27	.31	7	8	29'	9	1.7	6.1	.36	.42	9	11	20	6	1.1	4.1	.54	.63	14	16
	60	414	4.1	40'	12.2	2.5	9.3	.30	.34	8	9	30'	9	1.9	7.0	.39	.45	10	12	20	6	1.2	4.6	.59	.68	15	17
#3.0 Pre- installed	30	207	2.1	38'	11.6	2.0	7.6	.27	.31	7	8	29'	9	1.5	5.7	.36	.41	9	11	19	6	1.0	3.8	.53	.62	14	16
	40	276	2.8	38'	11.6	2.5	9.3	.33	.38	8	10	29'	9	1.8	7.0	.44	.50	11	13	19	6	1.2	4.6	.65	.75	17	19
	50	345	3.4	39'	11.9	2.7	10.2	.34	.39	9	10	29'	9	2.0	7.7	.46	.53	12	13	20	6	1.4	5.1	.68	.79	17	20
	60	414	4.1	42'	11.9	3.1	10.2	.33	.38	9	10	32'	10	2.3	8.7	.44	.51	11	13	21	6	1.5	5.8	.67	.77	17	20
#4.0	30	207	2.1	39'	11.9	3.1	11.8	.39	.45	10	12	29'	9	2.3	8.8	.52	.60	13	15	20	6	1.6	5.9	.79	.91	20	23
	40	276	2.8	40'	12.2	3.6	13.6	.43	.50	11	13	30'	9	2.7	10.2	.58	.67	15	17	20	6	1.8	6.8	.87	1.00	22	25
	50	345	3.4	41'	12.5	4.1	15.5	.47	.54	12	14	31'	9	3.1	11.7	.63	.72	16	18	21	6	2.1	7.8	.94	1.08	24	28
	60	414	4.1	43'	12.5	4.5	15.5	.47	.54	12	14	32'	10	3.4	12.8	.62	.72	16	18	22	7	2.3	8.5	.94	1.08	24	28
#6.0	30	207	2.1	41'	12.5	4.8	18.0	.54	.63	14	16	31'	9	3.6	13.5	.73	.84	18	21	21	6	2.4	9.0	1.09	1.26	28	32
	40	276	2.8	44'	13.4	5.4	20.5	.54	.62	14	16	33'	10	4.1	15.3	.72	.83	18	21	22	7	2.7	10.2	1.07	1.24	27	32
	50	345	3.4	46'	14.0	6.0	22.7	.55	.63	14	16	35'	11	4.5	17.1	.73	.84	19	21	23	7	3.0	11.4	1.10	1.26	28	32
	60	414	4.1	49'	14.9	6.7	25.4	.54	.62	14	16	37'	11	5.0	19.0	.72	.83	18	21	25	7	3.4	12.7	1.07	1.24	27	32
#8.0	30	276	2.8	42'	12.8	5.6	21.2	.61	.71	16	18	32'	10	4.2	15.9	.81	.94	21	24	21	6	2.8	10.6	1.22	1.41	31	36
	40	345	3.4	44'	13.4	6.5	24.6	.65	.75	16	19	33'	10	4.9	18.5	.86	1.00	22	25	22	7	3.3	12.3	1.30	1.49	33	38
	50	414	4.1	47'	14.3	7.4	28.1	.65	.75	16	19	35'	11	5.6	21.0	.86	.99	22	25	24	7	3.7	14.0	1.29	1.49	33	38
	60	483	4.8	51'	15.5	8.0	30.3	.59	.68	15	17	38'	12	6.0	22.7	.79	.91	20	23	26	8	4.0	15.2	1.84	1.37	30	35

Low Angle Performance Data

NOZZLE	PRESSURE PSI kPa Bar		NO ADJUSTMENT								-25% ADJUSTMENT								-50% ADJUSTMENT								
			RADIUS		FLOW		PRECIP in/hr mm/hr				RADIUS		FLOW		PRECIP in/hr mm/hr				RADIUS		FLOW		PRECIP in/hr mm/hr				
			Ft.	M.	GPM	L/M	■	▲	■	▲	Ft.	M.	GPM	L/M	■	▲	■	▲	Ft.	M.	GPM	L/M	■	▲	■	▲	
#1	30	207	2.1	22'	6.7	1.2	4.6	.48	.55	12	14	17'	5	0.9	3.4	.64	.73	16	19	11	3	0.6	2.3	.96	1.10	24	28
	40	276	2.8	24'	7.3	1.7	6.4	.57	.66	14	17	18'	5	1.3	4.8	.76	.87	19	22	12	4	0.9	3.2	1.14	1.31	29	33
	50	345	3.4	26'	7.9	1.8	6.8	.51	.59	13	15	20'	6	1.4	5.1	.68	.79	17	20	13	4	0.9	3.4	1.03	1.18	26	30
	60	414	4.1	28'	8.5	2.0	7.6	.49	.57	13	14	21'	6	1.5	5.7	.65	.76	17	19	14	4	1.0	3.8	.98	1.13	25	29
#3.0	30	207	2.1	29'	8.8	3.0	11.4	.69	.79	17	20	22'	7	2.3	8.2	.92	1.06	23	27	15	4	1.5	5.7	1.37	1.59	35	40
	40	276	2.8	32'	9.8	3.1	11.8	.58	.67	15	17	24'	7	2.3	8.8	.78	.90	20	23	16	5	1.6	5.9	1.17	1.35	30	34
	50	345	3.4	35'	10.7	3.5	13.6	.55	.64	14	16	26'	8	2.6	9.9	.73	.85	20	22	18	5	1.8	6.6	1.10	1.27	28	32
	60	414	4.1	37'	11.3	3.8	14.4	.53	.62	14	16	28'	8	2.9	10.8	.71	.82	18	21	19	6	1.9	7.2	1.07	1.23	27	31
#4.0	30	207	2.1	31'	9.4	3.9	14.8	.78	.90	20	23	23'	7	2.9	11.1	1.04	1.20	27	31	16	5	2.0	7.4	1.56	1.80	40	46
	40	276	2.8	34'	10.4	4.4	16.7	.73	.85	19	22	26'	8	3.3	12.5	.98	1.13	25	29	17	5	2.2	8.3	1.47	1.69	37	43
	50	345	3.4	37'	11.3	4.7	17.8	.66	.76	17	19	28'	8	3.5	13.4	.88	1.02	22	26	19	6	2.4	8.9	1.32	1.53	34	39
	60	414	4.1	38'	11.6	6.0	22.7	.80	.92	20	24	29'	9	4.5	17.1	1.07	1.23	27	31	19	6	3.0	11.4	1.60	1.85	41	47
#6.0	30	207	2.1	38'	11.6	6.5	24.6	.87	1.00	22	25	29'	9	4.9	18.5	1.16	1.33	29	34	19	6	3.3	12.3	1.73	2.00	45	51
	40	276	2.8	40'	12.2	7.3	27.7	.88	1.01	22	26	30'	9	5.5	20.8	1.17	1.35	30	34	20	6	3.7	13.8	1.76	2.03	47	52
	50	345	3.4	42'	12.8	8.0	30.3	.87	1.01	22	26	32'	10	6.0	22.7	1.16	1.34	30	34	21	6	4.0	15.2	1.75	2.02	44	51
	60	414	4.1	44'	13.4	8.6	32.6	.86	.99	22	25	33'	10	6.5	24.4	1.14	1.32	29	33	22	7	4.3	16.3	1.71	1.98	43	50

*All precipitation rates calculated for 180° operation. For the precipitation rate for a 360° sprinkler, divide by 2.

RPS® SELECT

Application: Residential / Light Commercial

RADIUS: 25' – 46'

FLOW: 1.3 – 6.8 GPM

INLET: 3/4"

K-Rain's new RPS® Select rotary sprinkler is the first gear-driven sprinkler that makes matched precipitation fast and easy, without the need for cumbersome changing of nozzles or sprinkler heads in the field. It offers a choice of 4 selectable built-in nozzles. With a twist of a flathead screwdriver, quickly select the correct nozzle flow to match the arc setting of the sprinkler, wet or dry. No nozzle trees to carry or lose. Fewer chances for errors. Using a combination of the four nozzles, it's easy to achieve matched precipitation across all arc settings.

The four on-board nozzles also make RPS® Select a convenient universal replacement sprinkler for other brands.



Features and Benefits

- **Four Built-in Selectable Nozzles** – Match different arc settings; nozzles #1 through #4 match arc settings 90° through 360°.
- **Adjustable Arc (40°-360°); All Adjustments Made From The Top** – Adjust wet or dry, no special tools needed.
- **Matched Precipitation Rates** – When nozzle setting matched to arc.
- **Precision-Engineered Nozzles** – Ensures water-saving efficiency.
- **Standard Rubber Cover**
- **Proven Water-lubricated Gear-drive Design** – Common to the popular RPS® 75 Series.
- **Riser Assembly Interchanges with Hunter® PGP® Rotors**
- **Low-pressure Operation**

Specifications

- Radius: 25' – 46'
- Flow rate: 1.3 – 6.8 GPM
- Recommended operating pressure: 25 – 75 PSI
- Optimum nozzle performance: 40 PSI
- Standard 4" pop-up for lawn areas
- 3/4" female-threaded inlet NPT
- Optional drain check valve controls up to 10' of elevation change
- Riser Height: 4"

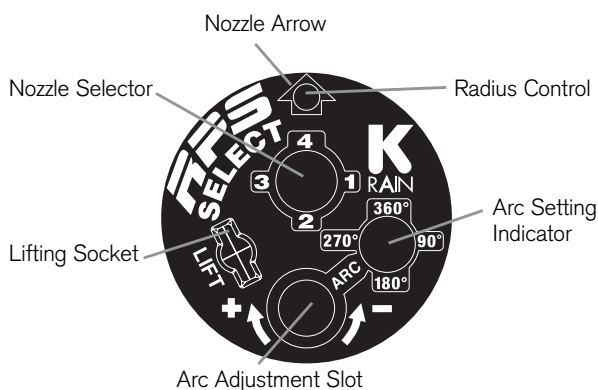

Models

60003 RPS® Select Rotor

OTHER OPTIONS: ADD TO PART NUMBER

-CV Check Valve

How to Specify

Model Number

60003

Description

-CV



The RPS® Select offers four pre-installed nozzles with greater water efficiency, allowing you to enjoy installation convenience and matched precipitation without hassles.



Performance Data

NOZZLE	PRESSURE			RADIUS		FLOW RATE			PRECIP in/hr		PRECIP mm/hr	
	PSI	kPa	Bars	Ft.	M.	GPM	L/M	M ³ /H	■	▲	■	▲
#1.0	30	207	2.1	33'	10.0	1.3	4.9	0.29	.23	.24	9	11
	35	241	2.4	34'	10.4	1.4	5.3	0.32	.23	.27	9	11
	40	276	2.8	37'	10.4	1.5	5.7	0.34	.21	.29	10	12
	45	310	3.1	37'	11.3	1.6	6.1	0.37	.22	.26	9	11
	50	345	3.4	37'	11.3	1.8	6.8	0.41	.25	.29	10	12
#2.0	30	207	2.1	37'	11.3	2.6	9.8	0.59	.37	.42	15	17
	35	241	2.4	38'	11.6	2.8	10.6	0.64	.37	.43	15	18
	40	276	2.8	39'	11.9	3.0	11.4	0.68	.38	.44	16	18
	45	310	3.1	40'	12.2	3.2	12.1	0.73	.39	.44	16	18
	50	345	3.4	40'	12.2	3.6	13.6	0.82	.43	.50	18	20
#3.0	30	207	2.1	37'	11.3	3.8	14.4	0.86	.53	.62	22	25
	35	241	2.4	40'	12.2	4.1	15.5	0.93	.49	.57	20	23
	40	276	2.8	41'	12.2	4.5	17.0	1.02	.52	.60	21	24
	45	310	3.1	41'	12.5	4.7	17.8	1.07	.54	.62	22	25
	50	345	3.4	43'	13.1	4.9	18.5	1.11	.51	.59	21	24
#4.0	30	207	2.1	38'	11.6	5.2	19.6	1.18	.69	.80	28	32
	35	241	2.4	40'	12.2	5.7	21.5	1.29	.69	.79	28	32
	40	276	2.8	44'	13.4	6.0	22.7	1.36	.60	.69	24	28
	45	310	3.1	45'	13.7	6.4	24.2	1.45	.61	.70	25	29
	50	345	3.4	46'	14.0	6.8	25.7	1.54	.62	.71	25	29

The ProPlus™ adjustable arc and continuous full-circle gear driven rotor comes standard with nine numerically coded interchangeable nozzles. Excellent nozzle performance delivers an exceptional fall out pattern. In independent testing by C.I.T., the ProPlus™ delivered up to 90% uniform coverage.

Tough, proven and advanced, the ProPlus™ is the leader in it's class. Set it and forget it. Arc Memory Clutch returns the rotor to its preset position. Technology works for you.



Features and Benefits

- **Revolutionary Patented Top Arc Set** – Simplified arc set allows for wet or dry adjustment in seconds.
- **5" Riser** – Perfect for grasses with thick thatch.
- **3/4" Inlet** – Replaces all standard rotors.
- **2N1 Adjustable or Continuous Rotation** – Provides a full range adjustment from 40° to a continuous full circle.
- **Patented Arc Set Degree Markings** – Clearly indicates current watering pattern & simplifies arc set adjustment.
- **Arc Memory Clutch** – Prevents internal gear damage and returns rotor to its prior setting automatically if nozzle turrets forced past its stop.
- **Time Proven Patented Reversing Mechanism** – Assures continuous reverse and return...over a 35 year history.
- **Ratcheting Riser** – Allows for easy adjustment of your fixed starting position with a simple turn of the riser.
- **Rubber Cover** – Seals out dirt, increases product durability.
- **Wide Selection of Nozzles** – Including standard and low angle, provides flexibility in system design.
- **Optional Check Valve** – Prevents low head drainage.

Specifications

- Inlet: 3/4" Threaded NPT
- Arc Adjustment Range: 40° to Continuous 360°
- Flow Range: .5 – 10.0 GPM
- Pressure Rating: 20 – 70 PSI
- Precipitation Rate: .06 – .50 Inches Per Hour (Depending on Spacing and Nozzle Used)
- Overall Height (Popped Down): 7 1/2" (17" for High Pop Model)
- Recommended Spacing: 28' – 44'
- Radius: 22' – 50'
- Nozzle Trajectory: 26°
- Low Angle Nozzle Trajectory: 12°
- Standard and Low Angle Nozzles Included
- Riser Height: 5"

Easy Arc Setting

Arc Selection 40° to Continuous 360°
Adjust From Left Start

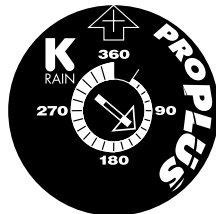

Models

11003	ProPlus™
11003-HP	ProPlus™ 12" High Pop
11003-SH	ProPlus™ Shrub Head

OTHER OPTIONS: ADD TO PART NUMBER

-CV	Check Valve
-LA	Low Angle Nozzle
-NN	No Nozzle
-RCW	Reclaimed Water Use

How to Specify

Model Number

11003

Description

-RCW



Performance Data

NOZZLE	PRESSURE			RADIUS		FLOW RATE			PRECIP in/hr		PRECIP mm/hr	
	PSI	kPa	Bars	Ft.	M.	GPM	L/M	M ³ /H	■	▲	■	▲
#0.5	30	207	2.1	28'	8.5	0.5	1.9	0.11	0.12	0.14	5	6
	40	276	2.8	29'	8.8	0.6	2.3	0.14	0.14	0.16	6	6
	50	345	3.5	29'	8.8	0.7	2.7	0.16	0.16	0.19	7	8
	60	414	4.1	30'	9.1	0.8	3.0	0.18	0.17	0.20	7	8
#0.75	30	207	2.1	29'	8.8	0.7	2.7	0.16	0.16	0.19	7	8
	40	275	2.8	30'	9.1	0.8	3.0	0.18	0.17	0.20	7	8
	50	344	3.4	31'	9.4	0.9	3.4	0.20	0.18	0.21	7	8
	60	413	4.1	32'	9.8	1.0	3.8	0.23	0.19	0.22	8	9
#1.0	30	207	2.1	32'	9.8	1.3	4.9	0.30	0.24	0.28	10	12
	40	275	2.8	33'	10.1	1.5	5.7	0.34	0.27	0.31	11	12
	50	344	3.4	34'	10.4	1.6	6.1	0.36	0.27	0.31	11	13
	60	413	4.1	35'	10.7	1.8	6.8	0.41	0.28	0.33	12	13
#2.0	30	207	2.1	37'	11.3	2.4	9.1	0.55	0.34	0.39	14	16
	40	275	2.8	40'	12.2	2.5	9.5	0.57	0.30	0.35	12	14
	50	344	3.4	42'	12.8	3.0	11.4	0.68	0.33	0.38	13	15
	60	413	4.1	43'	13.1	3.3	11.4	0.68	0.34	0.36	13	15
2.5 Pre-installed	30	207	2.1	38'	11.6	2.5	9.5	0.57	0.33	0.38	14	16
	40	275	2.8	39'	11.9	2.8	10.6	0.64	0.35	0.41	14	17
	50	344	3.4	40'	12.2	3.2	12.1	0.73	0.39	0.44	16	18
	60	413	4.1	41'	12.5	3.5	13.3	0.80	0.40	0.46	16	19
#3.0	30	207	2.1	38'	11.6	3.6	13.6	0.82	0.48	0.55	20	23
	40	275	2.8	39'	11.9	4.2	15.9	0.96	0.53	0.61	22	25
	50	344	3.4	41'	12.5	4.6	17.4	1.05	0.53	0.61	21	25
	60	413	4.1	42'	12.8	5.0	19.0	1.14	0.55	0.63	22	26
#4.0	30	207	2.1	43'	13.1	4.4	16.7	1.00	0.46	0.53	19	22
	40	275	2.8	44'	13.4	5.1	19.3	1.16	0.51	0.59	21	24
	50	344	3.4	46'	14.0	5.6	21.2	1.27	0.51	0.59	21	24
	60	413	4.1	49'	14.9	5.9	22.4	1.34	0.47	0.55	19	22
#6.0	40	276	2.8	45'	13.7	5.9	22.4	1.34	0.56	0.65	23	26
	50	344	3.4	46'	14.0	6.0	22.7	1.36	0.55	0.63	22	26
	60	413	4.1	48'	14.6	6.3	23.9	1.43	0.53	0.61	21	25
	70	482	4.8	49'	14.9	6.7	25.4	1.52	0.54	0.62	22	25
#8.0	40	276	2.8	42'	12.8	8.0	30.3	1.82	0.87	1.01	36	41
	50	344	3.4	45'	13.7	8.5	32.2	1.93	0.81	0.93	33	38
	60	413	4.1	49'	14.9	9.5	36.0	2.16	0.76	0.88	31	36
	70	482	4.8	50'	15.2	10.0	37.9	2.27	0.77	0.89	31	36



Low Angle Performance Data

NOZZLE	PRESSURE			RADIUS		FLOW RATE			PRECIP in/hr		PRECIP mm/hr	
	PSI	kPa	Bars	Ft.	M.	GPM	L/M	M ³ /H	■	▲	■	▲
#1.0	30	207	2.1	22'	6.7	1.2	4.5	.27	0.48	0.55	6.7	19
	40	276	2.8	24'	7.3	1.7	6.4	.39	0.57	0.66	7.3	23
	50	345	3.4	26'	7.9	1.8	6.8	.41	0.51	0.59	7.9	21
	60	414	4.1	28'	8.5	2.0	7.6	.45	0.49	0.57	8.5	20
#2.0	30	207	2.1	29'	8.8	3.0	11.4	.68	0.69	0.79	8.8	28
	40	276	2.8	32'	9.8	3.1	11.7	.70	0.58	0.67	9.8	24
	50	345	3.4	35'	10.7	3.5	13.2	.80	0.55	0.64	10.7	22
	60	414	4.1	37'	11.3	3.8	14.4	.86	0.53	0.62	11.3	22
#4.0	30	207	2.1	31'	9.4	3.4	12.9	.77	0.68	0.79	9.4	28
	40	276	2.8	34'	10.4	3.9	14.8	.89	0.65	0.75	10.4	26
	50	345	3.4	37'	11.3	4.4	16.7	1.00	0.62	0.71	11.3	25
	60	414	4.1	38'	11.6	4.7	17.8	1.07	0.63	0.72	11.6	26
#6.0	40	275	2.8	38'	11.6	6.5	24.6	1.48	0.87	1.00	11.6	35
	50	344	3.4	40'	12.2	7.3	27.7	1.66	0.88	1.01	12.2	36
	60	413	4.1	42'	12.8	8.0	30.3	1.82	0.87	1.01	12.8	36
	70	482	4.8	44'	13.4	8.6	32.6	1.96	0.86	0.99	13.4	35

*All precipitation rates calculated for 180° operation. For the precipitation rate for a 360° sprinkler, divide by 2.

The ProPlus™ is packed with features which ensures reliability; saving the installer time and money on every job.

SuperPro™ with Intelligent Flow Technology® and patented Flow Control allows the reduction of distance while simultaneously and proportionately reducing the flow rate down 50%! Water savings of up to 30% or more is achievable with this innovative feature. SuperPro™ delivers even water distribution, eliminates dry spots and provides better zone performance. Water flow can be turned off during installation or adjustment, with the riser remaining in popped-up position for quick nozzle changes.



Features and Benefits

- **Revolutionary Patented Easy Arc Set** – Simplified arc set allows for wet or dry adjustment in seconds.
- **2N1 Adjustable or Continuous Rotation** – Provides a full range of adjustment from 40° to continuous 360°.
- **Patented Arc Set Degree Markings** – Clearly indicates current watering pattern, simplifies arc set adjustment.
- **Arc Memory Clutch** – Prevents internal gear damage and returns rotor to its prior setting automatically if nozzle turret is forced out of adjustment.
- **Time Proven Patented Reversing Mechanism** – Assures continuous reverse and return...over a 35 year history.
- **Ratcheting Riser** – Allows for easy adjustment of your left starting position with a simple turn of the riser.
- **Rubber Cover** – Seals out dirt and increases product durability.
- **Optional Check Valve** – Prevents low head drainage.
- **Rugged Stainless Steel Spring** – .093 gauge 302 stainless steel spring extends the life of the rotor.

Easy Arc Setting

Arc Selection 40°
to Continuous 360°
Adjust From Left Start



Intelligent Flow
Technology®

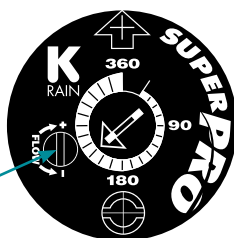

- Reduces distance and flow rate proportionately
- Provides full on/off control

Models

10003 SuperPro™

OTHER OPTIONS: ADD TO PART NUMBER

-HP	12" High Pop
-SH	Shrub Head
-CV	Check Valve
-NN	No Nozzle
-RCW	Reclaimed Water Use

Specifications

- Inlet: 3/4" Threaded NPT
- Arc Adjustment Range: 40° to Continuous 360°
- Flow Range: .5 – 9.5 GPM
- Pressure Rating: 20 – 70 PSI
- Precipitation Rate: .13 – 1.48 Inches Per Hour (Depending on Spacing and Nozzle Used)
- Overall Height (Popped Down): 7 1/2"
- Recommended Spacing: 28' – 44'
- Radius: 26' – 49'
- Nozzle Trajectory: 26°
- Low Angle Nozzle Trajectory: 12°
- Standard and Low Angle Nozzles Included
- Riser Height: 5"

How to Specify

Model Number	Description
10003	-RCW



Performance Data

NOZZLE	PRESSURE			RADIUS		FLOW RATE			PRECIP in/hr		PRECIP mm/hr	
	PSI	kPa	Bars	Ft.	M.	GPM	L/M	M ³ /H	■	▲	■	▲
#0.5	30	207	2.1	26'	9.1	0.5	1.70	0.10	0.13	0.15	5	6
	40	276	2.8	26'	8.8	0.5	1.89	0.11	0.14	0.16	6	7
	50	345	3.5	29'	7.9	0.6	2.27	0.14	0.14	0.16	6	7
	60	414	4.1	30'	7.9	0.7	2.65	0.16	0.15	0.17	6	7
#0.75	30	207	2.1	32'	9.8	0.7	2.65	0.16	0.13	0.15	5	6
	40	276	2.8	32'	9.8	0.8	3.03	0.18	0.15	0.17	6	7
	50	345	3.4	33'	10.1	0.9	3.41	0.20	0.16	0.18	6	7
	60	414	4.1	33'	10.1	1.0	3.79	0.23	0.18	0.20	7	8
#1.0	30	207	2.1	30'	9.1	1.1	4.16	0.25	0.24	0.27	10	11
	40	276	2.8	32'	9.8	1.3	4.92	0.30	0.24	0.28	10	11
	50	345	3.4	33'	10.1	1.5	5.68	0.34	0.27	0.31	11	12
	60	414	4.1	33'	10.1	1.6	6.06	0.36	0.28	0.33	11	13
#2.0	30	207	2.1	38'	11.6	2.3	8.71	0.52	0.31	0.35	12	14
	40	276	2.8	38	11.6	2.5	9.46	0.57	0.33	0.38	14	16
	50	345	3.4	40'	12.2	2.7	10.22	0.61	0.32	0.38	13	15
	60	414	4.1	42'	12.8	3.0	11.36	0.68	0.33	0.38	13	15
2.5 Pre-installed	30	207	2.1	35'	10.7	2.5	9.46	0.57	0.39	0.45	16	18
	40	276	2.8	36'	11.0	2.8	10.60	0.64	0.42	0.48	17	19
	50	345	3.4	37'	11.3	3.2	12.11	0.73	0.45	0.52	18	21
	60	414	4.1	38'	11.6	3.6	13.63	0.82	0.48	0.55	19	23
#3.0	30	207	2.1	35'	10.7	3.4	12.87	0.77	0.53	0.62	22	25
	40	276	2.8	36'	11.0	3.8	14.38	0.86	0.56	0.65	23	26
	50	345	3.4	38'	11.6	4.2	15.90	0.95	0.56	0.65	23	26
	60	414	4.1	39'	11.9	4.8	18.17	1.09	0.61	0.70	25	29
#4.0	30	207	2.1	42'	12.8	4.1	15.52	0.93	0.45	0.52	18	21
	40	276	2.8	44'	13.4	4.6	17.41	1.04	0.46	0.53	19	22
	50	345	3.4	45'	13.7	5.1	19.31	1.16	0.48	0.56	20	23
	60	414	4.1	46'	14.0	5.7	21.58	1.29	0.52	0.60	21	24
#6.0	40	276	2.8	46'	14.0	5.8	21.96	1.32	0.53	0.61	22	25
	50	345	3.4	48'	14.6	6.4	24.23	1.45	0.53	0.62	22	25
	60	414	4.1	49'	14.9	7.0	26.50	1.59	0.56	0.65	23	27
	70	483	4.8	49'	14.9	7.5	28.39	1.70	0.60	0.69	25	28
#8.0	40	276	2.8	42'	12.8	7.5	28.39	1.70	0.82	0.95	33	39
	50	345	3.4	45'	13.7	8.2	31.04	1.86	0.78	0.90	32	37
	60	414	4.1	48'	14.6	9.0	34.07	2.04	0.75	0.87	31	36
	70	483	4.8	48'	14.6	9.5	35.96	2.16	0.79	0.92	32	37



Low Angle Performance Data

NOZZLE	PRESSURE			RADIUS		FLOW RATE			PRECIP in/hr		PRECIP mm/hr	
	PSI	kPa	Bars	Ft.	M.	GPM	L/M	M ³ /H	■	▲	■	▲
#1.0	30	207	2.1	26'	7.9	1.3	4.9	.3	0.37	0.43	15	18
	40	276	2.8	27'	8.2	1.5	5.7	.3	0.40	0.46	16	19
	50	345	3.4	27'	8.2	1.7	6.4	.4	0.45	0.52	18	21
	60	414	4.1	28'	8.5	1.9	7.2	.4	0.47	0.54	19	22
#3.0	30	207	2.1	29'	8.8	2.9	11.0	.7	0.66	0.77	27	32
	40	276	2.8	30'	9.1	3.3	12.5	.7	0.71	0.82	29	34
	50	345	3.4	31'	9.4	3.4	12.9	.8	0.68	0.79	28	32
	60	414	4.1	33'	10.1	4.0	15.1	.9	0.71	0.82	29	33
#4.0	30	207	2.1	28'	8.5	4.0	15.1	.9	0.98	1.13	40	47
	40	276	2.8	31'	9.4	4.7	17.8	1.1	0.94	1.09	39	45
	50	345	3.4	34'	10.4	5.0	18.9	1.1	0.83	0.96	34	39
	60	414	4.1	36'	11.0	6.0	22.7	1.4	0.89	1.03	36	42
#6.0	40	276	2.8	30'	9.1	6.0	22.7	1.4	1.28	1.48	53	61
	50	345	3.4	34'	10.4	7.0	26.5	1.6	1.17	1.35	47	54
	60	414	4.1	37'	11.3	7.8	29.5	1.8	1.10	1.27	45	51
	70	483	4.8	38'	11.6	8.2	31.0	1.9	1.09	1.26	44	51

*All precipitation rates calculated for 180° operation. For the precipitation rate for a 360° sprinkler, divide by 2.



Intelligent Flow Technology® allows distance and water flow to be reduced simultaneously.

PROSPORT™

Application: Sports Turf

RADIUS: 45' – 77'

FLOW: 5.1 – 32.5 GPM

INLET: 1"

The ProSport™ comes standard with a unique triple nozzle configuration, consisting of a primary nozzle for long distance and two secondary nozzles for mid-range and short distance coverage. This nozzle design provides even water distribution from 45' to 77'.

Available in a high speed version, ideal for quick wet downs and dust control.



Features and Benefits

- **Revolutionary Patented Top Arc Set** – Simplified arc set allows for wet or dry adjustment in seconds.
- **Triple Nozzle Configuration** – Ensures even distribution of water.
- **2N1 Adjustable or Continuous Rotation** – Provides a full range of adjustment from 40° to a continuous full circle.
- **Top Arc Set Degree Markings** – Clearly indicates the current watering pattern and simplifies arc set adjustment.
- **Arc Memory Clutch** – Prevents internal gear damage and returns rotor to its prior setting automatically if nozzle turret is forced past stop.
- **Time Proven Patented Reversing Mechanism** – Assures continuous reverse and return...over a 35 year history.
- **Ratcheting Riser** – Allows for easy adjustment of your fixed starting position with a simple turn of the riser.
- **Heavy Duty Rubber Cover and Mud Guard** – Protects against physical injury and reduces liability, allows sprinkler to be installed below grade.
- **Factory Installed Check Valve** – Prevents low head drainage.

Specifications

- Inlet: 1" Threaded NPT Domestic
1" Threaded BSP International
- Arc Adjustment Range: 40° to Continuous 360°
- Flow Range: 5.1 – 32.5 GPM
- Pressure Rating: 40 – 90 PSI
- Precipitation Rate: .48 – 1.35 in./hr.
(Depending on Spacing & Nozzle Used)
- Overall Height (Popped Down): 9 1/2"
- Recommended Spacing: 40' – 65'
- Radius: 45' – 77'
- Nozzle Trajectory: 26°
- Riser Height: 4"

Easy Arc Setting

Arc Selection 40° to 360°
Adjust From Left Start

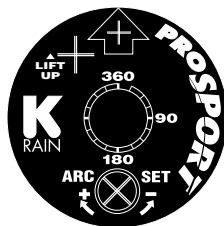

Models

- 14003 ProSport™ Plastic
- 14053 ProSport™ High Speed Plastic

OTHER OPTIONS: ADD TO PART NUMBER







- SS Stainless Steel
- BSP w/BSP Thread
- NN No Nozzle
- RCW Reclaimed Water Use

How to Specify







Model Number	Description
14003	-SS



Performance Data - Model 14003

NOZZLE	PRESSURE			RADIUS		FLOW RATE			PRECIP in/hr		PRECIP mm/hr	
	PSI	kPa	Bars	Ft.	M.	GPM	L/M	M ³ /H	■	▲	■	▲
 #5	40	276	2.8	45'	13.7	5.1	19.3	1.2	0.48	0.58	20	23
	50	345	3.5	47'	14.3	5.9	22.3	1.3	0.51	0.62	21	24
	60	414	4.1	47'	14.3	6.5	24.6	1.5	0.57	0.68	23	27
	70	483	4.8	49'	14.9	7.1	26.9	1.6	0.57	0.68	23	27
 #10 Pre-installed	50	345	3.5	53'	16.2	10.6	40.1	2.4	0.73	0.87	29	34
	60	414	4.1	53'	15.9	11.8	44.7	2.7	0.81	0.97	34	39
	70	483	4.8	53'	16.2	12.6	47.7	2.9	0.86	1.04	35	40
	80	552	5.5	55'	16.8	13.5	51.1	3.1	0.86	1.03	35	40
 #15	50	345	3.5	57'	17.4	13.0	49.2	3.0	0.77	0.92	31	36
	60	414	4.1	59'	18.0	14.2	53.8	3.2	0.79	0.94	32	37
	70	483	4.8	59'	18.0	15.4	58.3	3.5	0.85	1.02	35	40
	80	552	5.5	63'	19.2	16.5	62.5	3.8	0.80	0.96	33	38
 #20	60	414	4.1	65'	19.8	18.9	71.5	4.3	0.86	1.03	35	41
	70	483	4.8	67'	20.4	20.5	77.6	4.7	0.88	1.06	36	41
	80	552	5.5	69'	21.0	21.9	82.9	5.0	0.89	1.06	36	42
	90	621	6.2	71'	21.6	23.2	87.8	5.3	0.89	1.06	36	42
 #25	60	414	4.1	67'	20.4	22.8	86.3	5.2	0.98	1.17	40	46
	70	483	4.8	71'	21.6	24.8	93.9	5.6	0.95	1.14	39	45
	80	552	5.5	75'	22.9	26.5	100.3	6.0	0.91	1.09	37	43
	90	621	6.2	77'	23.5	26.8	101.4	6.1	0.87	1.04	35	41
 #30	60	414	4.1	67'	20.4	23.7	89.7	5.4	1.02	1.22	41	48
	70	483	4.8	69'	21.0	25.6	96.9	5.8	1.04	1.24	42	49
	80	552	5.5	69'	21.0	27.5	104.1	6.3	1.11	1.33	45	52
	90	621	6.2	71'	21.6	29.2	110.5	6.6	1.12	1.34	46	53

Performance Data - Model 14053

NOZZLE	PRESSURE			RADIUS		FLOW RATE			PRECIP in/hr		PRECIP mm/hr	
	PSI	kPa	Bars	Ft.	M.	GPM	L/M	M ³ /H	■	▲	■	▲
 #5	40	276	2.8	43'	13.1	5.9	22.3	1.3	0.61	0.71	25	29
	50	345	3.5	44'	13.4	6.2	23.5	1.4	0.62	0.71	25	29
	60	414	4.1	45'	13.7	6.4	24.2	1.5	0.61	0.70	25	29
	70	483	4.8	45'	13.7	7.6	28.8	1.7	0.72	0.83	30	34
 #10 Pre-installed	50	345	3.5	49'	14.9	10.6	40.1	2.4	0.85	0.98	35	40
	60	414	4.1	53'	15.8	11.5	44.3	2.7	0.79	0.91	34	39
	70	483	4.8	53'	16.1	13.3	50.3	3.0	0.91	1.05	37	43
	80	552	5.5	54'	16.5	14.0	53.0	3.2	0.92	1.07	37	43
 #15	50	345	3.5	52'	15.8	12.4	46.9	2.8	0.88	1.02	36	42
	60	414	4.1	54'	16.5	13.6	55.3	3.3	0.90	1.04	39	45
	70	483	4.8	56'	17.1	14.6	58.7	3.5	0.90	1.03	39	45
	80	552	5.5	58'	17.1	15.9	60.2	3.6	0.91	1.05	37	43
 #20	60	414	4.1	56'	17.1	19.8	66.2	4.0	1.22	1.40	44	50
	70	483	4.8	58'	17.7	21.2	71.5	4.3	1.21	1.40	44	51
	80	552	5.5	59'	18.0	22.8	78.7	4.7	1.26	1.46	47	54
	90	621	6.2	60'	18.3	24.4	82.1	4.9	1.30	1.51	47	55
 #25	60	414	4.1	59'	18.0	22.4	84.8	5.1	1.24	1.43	50	58
	70	483	4.8	66'	20.1	25.7	97.3	5.8	1.14	1.31	46	54
	80	552	5.5	67'	20.4	27.8	105.2	6.3	1.19	1.38	49	56
	90	621	6.2	68'	20.7	29.9	113.2	6.8	1.24	1.44	51	59
 #30	60	414	4.1	60'	18.3	25.2	95.4	5.7	1.35	1.56	55	63
	70	483	4.8	72'	22.0	28.5	107.9	6.5	1.06	1.22	43	50
	80	552	5.5	73'	22.2	30.8	116.6	7.0	1.11	1.28	46	53
	90	621	6.2	75'	22.9	32.5	123.0	7.4	1.11	1.28	45	52

*All precipitation rates calculated for 180° operation. For the precipitation rate for a 360° sprinkler, divide by 2.



Designed specifically for sports turf, with head spacing from 40' to 65'

PRO-S™ SPRAYS

Application: Residential / Light Commercial

PRESSURE: 20 – 70 PSI

INLET: 1/2"

The result of precision engineering and extensive field testing by contractors around the world, the Pro-S™ is designed to provide long life and outstanding performance. These sprays are distinguished by robust construction, rugged body and cap, co-molded seal and heavy-duty retraction spring. Built with the contractor in mind.

The co-molded wiper seal ensures proper operation time after time with minimal flow by.

Compatible with all standard female-thread nozzles.



Models

- 78002 PRO-S™ 2" Pop-up (5 cm)
- 78003 PRO-S™ 3" Pop-up (7.5 cm)
- 78004 PRO-S™ 4" Pop-up (10 cm)
- 78006 PRO-S™ 6" Pop-up with side inlet (15 cm)
- 78012 PRO-S™ 12" Pop-up (30 cm)

Other options add to part number:

- CV Check Valve
- GUARD Nozzle Guard
- NSI No Side Inlet (6" only)
- PR Pressure Regulator (4", 6" & 12") regulates to 40 PSI
- RCW Reclaimed Water Use

Features and Benefits

- **Co-Molded Wiper Seal** – Ensures a leak free, full pop-up operation even under low-pressure situations. Cartridge design allows for easy removal and cleaning. Treated with UV inhibitors for long life. Seal is microbe resistant to reduce degradation and stick-ups.
- **Accepts Female Threaded Nozzles**
- **Ratcheting Riser** – Permits quick, easy alignment of spray pattern.
- **Heavy-Duty Retraction Spring** – Strongest spring in the industry for positive retraction in all soil conditions.
- **Side Inlet** – Standard on 12" model.
- **NEW!** 6" model available with or without side inlet.
- **Wide Selection of Sizes** – Available in 2", 3", 4", 6" and 12" models.
- **Pre-Installed Flush Cap**
- **Optional In-stem Pressure Regulator** – Available for 4", 6" and 12" models, factory preset at 40 psi.
- **Optional In-stem Check Valve** – Installs in the field, holds up to 10' of head pressure.
- **Optional Pre-installed Nozzle Guard**
- **Fits in Rainbird 1800 Can**

Specifications

- Pressure Rating: 20 – 70 PSI
- Flow-by: 0 – 8 psi (0.6 bar) 0.20 gpm
- Inlet: 1/2" Female Thread NPT
- Overall Body Height:
 - 78002 – 4" 78006 – 9 3/8"
 - 78003 – 4 7/8" 78012 – 16"
 - 78004 – 6"

How to Specify:

Model Number	Description
78003	-CV

Optional Features

Shrub Adapter
part # PFSA





Pad printed CV-PR (optional, shown above) is easily identified in the field after installation.

The Pro-S™ Spray is designed to provide long life and outstanding performance. Save water and eliminate misting and low head drainage with Pro-S™ CV-PR model.



Co-Molded Wiper Seal

Ensures leak free, full pop-up operation even under low-pressure situations. The unique cartridge design features a microbe-resistant, durable material preventing degradation and stick-ups.

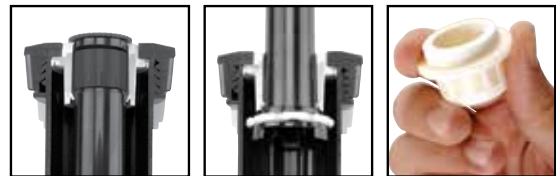

Optional Features



In-stem Pressure Regulation – Saves water by properly regulating nozzle operating pressure. In-stem pressure regulation aids in eliminating misting, fogging and overspray due to wind drift. Regulates pressure to 40 PSI.

Nozzle Guard – Provides extra protection to Rotary or standard nozzles.



NP SPRAYS

Application: Residential / Light Commercial

PRESSURE: 20 – 50 PSI

INLET: 1/2"

NP pop-up sprays are built with the contractor in mind. With the narrow profile, replacement is effortless. The durable microbe-resistant seal ensures leak-free operation and extends product life.



Features and Benefits

- Available in 2" and 4" Models – Provides flexibility in system design.
- Accepts Female Threaded Nozzles.
- Stainless Steel Retraction Spring – Provides reliable retraction of the riser in all soil conditions.
- Ratcheting Riser – Allows for easy pattern alignment by turning the riser.
- Narrow Profile Body – Easy to retrofit with existing systems.

Specifications

- Pressure Rating: 20 – 50 PSI
- Inlet: 1/2" NPT Male Thread
- Overall Body Height:
 - NP2 – 2"
 - NP4 – 4"

Models

NP2 2" Narrow Profile Spray Body

NP4 4" Narrow Profile Spray Body

Other options add to part number:

-CV Check Valve

Optional Features

Shrub Adapter
part # PFSA



How to Specify:

Model Number	Description
NP2	-CV



NP Sprays and K-Sprays are ideal for watering smaller areas, ground cover and shrub areas.

K-SPRAYS

Application: Residential / Light Commercial

PRESSURE: 20 – 50 PSI

INLET: 1/2"

The K-Spray line offers system versatility with a wide range of pop-up heights suited for many applications from small flower beds to residential and light commercial lawns and planted areas. Manufactured with time-tested UV-resistant plastic and corrosion resistant stainless steel parts for long product life and reliability.

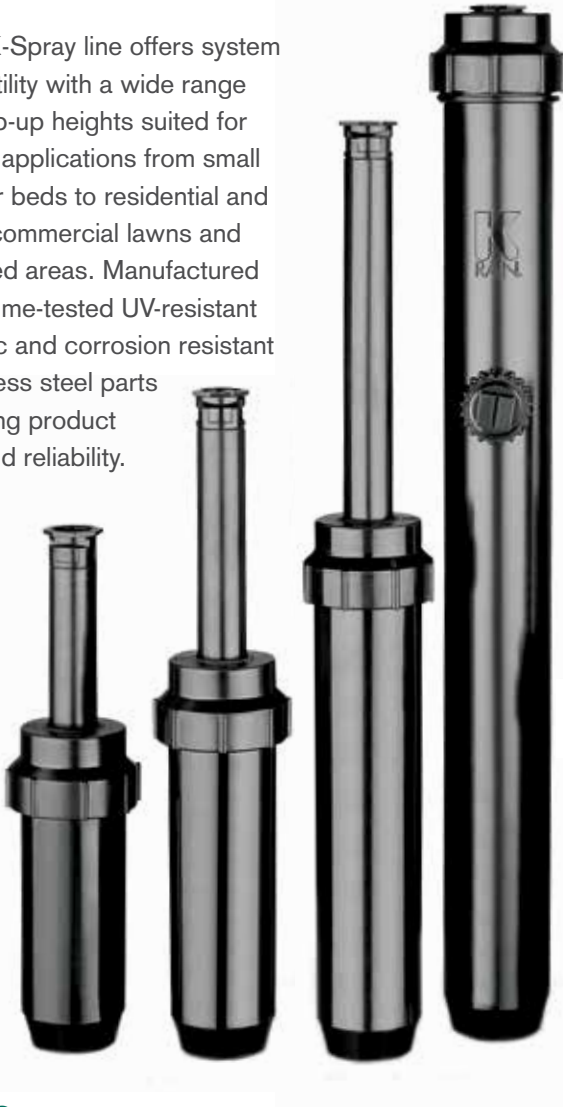

Features and Benefits

- Available in 3", 4", 6" and 12" Models – Provides flexibility in system design.
- Accepts Male Threaded Nozzles.
- **Stainless Steel Retraction Spring** – Provides reliable retraction of the riser in all soil conditions.
- **Ratcheting Riser** – Allows for easy pattern alignment by turning the riser.
- **Heavy Duty Wiper Seal** – Ensures leak free, full pop-up operation even under low-pressure situations.
- **Optional Water-Saving Check Valve** – Increases system water efficiency.
- **Optional Purple Cap for Reclaimed Water Use** – Highly visible for identification of RCW systems.

Specifications

- Pressure Rating: 20 – 50 PSI
- Inlet: 1/2" NPT Female Thread
- Overall Body Height:
 - 73001 – 3"
 - 74001 – 4"
 - 76001 – 6"
 - 71201 – 12"

How to Specify:

Model Number	Description
73001	-RCW

Models

73001	3" Pop-Up
74001	4" Pop-Up
76001	6" Pop-Up
71201	12" Pop-Up

Other Options: Add to Part Number

-RCW	Reclaimed Water Use / Purple Cap
-CV	Check Valve

Optional Features

Shrub Adapter
part # PSA



K-Spray bodies accept male thread nozzles such as K-Rain's KV Adjustable Nozzles. The KV Adjustable Nozzles have superior spray patterns and matched precipitation rates throughout the adjustment. They are available in 8', 10', 12', 15' and 17' models.

ROTARY NOZZLE SERIES

Application: Residential / Light Commercial

K-Rain's series is the only combination of rotary nozzles allowing the contractor to carry fewer sku's in their trucks. The 90° – 270° adjustable arc will fulfill 80% – 90% of all arc adjustments usually required! The full 360° and specialty models complete the variety of pattern options.



Models

RN100 ADJ-90-270	Adjustable 90° - 270° 13' – 15' (Medium Green)
RN100 FIX 360	Fixed Pattern 360° 13' – 15' (Light Green)
RN200 ADJ-90-270	Adjustable 90° - 270° 16' – 19' (Medium Blue)
RN200 FIX 360	Fixed Pattern 360° 16' – 19' (Light Blue)
RN300 ADJ-90-270	Adjustable 90° - 270° 26' – 30' (Medium Grey)
RN300 FIX 360	Fixed Pattern 360° 26' – 30' (Light Grey)
RNS-RES-515	Right End Strip (Burnt Orange)
RNS-LES-515	Left End Strip (Olive)
RNS-SS-530	Side Strip (Brown)

Features and Benefits

- **Durable Design** – Molded with high-impact engineered resin and other high quality plastics for long life.
- **Superior Uniformity** – Multi-stream technology provides outstanding coverage eliminating brown spots.
- **Matched Precipitation** – Low precipitation rate is proportionate even after arc and radius adjustment.
- **Water-smart Technology** – Reduce water usage up to 30% without sacrificing turf quality.
- **Double pop-up Design** – Delivers additional protection from dirt/particulate intrusion and harsh conditions.
- **Simple to Adjust** – Easiest adjustment in the industry.
- **Color-Coded** – Easily identify 6 standard nozzles and 3 specialty nozzles in the field.

Performance Data - Adjustable and Fixed Patterns

RN100-ADJ-90-270 (MEDIUM GREEN)

ARC	PRESSURE			RADIUS		FLOW RATE		PRECIP in/hr		PRECIP mm/hr	
	PSI	kPa	Bars	Ft.	M.	GPM	L/M	■	▲	■	▲
90°	30	207	2.07	13	3.96	0.22	0.83	0.50	0.58	12.70	14.73
	35	241	2.41	14	4.27	0.24	0.91	0.46	0.53	11.68	13.46
	40	276	2.76	14	4.27	0.25	0.94	0.49	0.57	12.44	14.48
	45	310	3.10	15	4.57	0.29	1.10	0.49	0.57	12.44	14.48
	50	345	3.45	15	4.57	0.30	1.13	0.51	0.59	12.95	14.98
180°	30	207	2.07	13	3.96	0.44	1.66	0.50	0.58	12.70	14.73
	35	241	2.41	14	4.27	0.47	1.78	0.46	0.53	11.68	13.46
	40	276	2.76	14	4.27	0.50	1.89	0.49	0.57	12.44	14.48
	45	310	3.10	15	4.57	0.58	2.19	0.49	0.57	12.44	14.48
	50	345	3.45	15	4.57	0.60	2.27	0.51	0.59	12.95	14.98
270°	30	207	2.07	13	3.96	0.66	2.50	0.50	0.58	12.70	14.73
	35	241	2.41	14	4.27	0.71	2.69	0.46	0.53	11.68	13.46
	40	276	2.76	14	4.27	0.75	2.84	0.49	0.57	12.44	14.48
	45	310	3.10	15	4.57	0.86	3.25	0.49	0.57	12.44	14.48
	50	345	3.45	15	4.57	0.90	3.40	0.51	0.59	12.95	14.98

RN100-FIX360 (LIGHT GREEN)

ARC	PRESSURE			RADIUS		FLOW RATE		PRECIP in/hr		PRECIP mm/hr	
	PSI	kPa	Bars	Ft.	M.	GPM	L/M	■	▲	■	▲
360°	30	207	2.07	13	3.96	0.88	3.33	0.50	0.58	12.70	14.73
	35	241	2.41	14	4.27	0.94	3.56	0.46	0.53	11.68	13.46
	40	276	2.76	14	4.27	1.00	3.78	0.49	0.57	12.44	14.48
	45	310	3.10	15	4.57	1.15	4.35	0.49	0.57	12.44	14.48
	50	345	3.45	15	4.57	1.20	4.54	0.51	0.59	12.95	14.98

*Data represents test results in zero wind. Adjust for local conditions. Radius may be reduced with the nozzle retention screw.





Performance Data - Adjustable and Fixed Patterns

RN200-ADJ-90-270 (MEDIUM BLUE)

ARC	PRESSURE			RADIUS		FLOW RATE		PRECIP in/hr		PRECIP mm/hr	
	PSI	kPa	Bars	Ft.	M.	GPM	L/M	■	▲	■	▲
90°	30	207	2.07	16	4.87	0.34	1.29	0.50	0.58	12.70	14.73
	35	241	2.41	17	5.18	0.38	1.44	0.50	0.58	12.70	14.73
	40	276	2.76	18	5.48	0.41	1.55	0.49	0.57	12.44	14.48
	45	310	3.10	19	5.79	0.42	1.59	0.45	0.52	11.43	13.21
	50	345	3.45	19	5.79	0.47	1.78	0.50	0.58	12.70	14.73
180°	30	207	2.07	16	4.87	0.67	2.53	0.50	0.58	12.70	14.73
	35	241	2.41	17	5.18	0.75	2.84	0.50	0.58	12.70	14.73
	40	276	2.76	18	5.48	0.83	3.14	0.49	0.57	12.44	14.48
	45	310	3.10	19	5.79	0.84	3.18	0.45	0.52	11.43	13.21
	50	345	3.45	19	5.79	0.94	3.56	0.50	0.58	12.70	14.73
270°	30	207	2.07	16	4.87	1.01	3.82	0.50	0.58	12.70	14.73
	35	241	2.41	17	5.18	1.13	4.28	0.50	0.58	12.70	14.73
	40	276	2.76	18	5.48	1.24	4.69	0.49	0.57	12.44	14.48
	45	310	3.10	18	5.48	1.26	4.77	0.50	0.58	12.70	14.73
	50	345	3.45	19	5.79	1.41	5.34	0.50	0.58	12.70	14.73

RN200-FIX360 (LIGHT BLUE)

ARC	PRESSURE			RADIUS		FLOW RATE		PRECIP in/hr		PRECIP mm/hr	
	PSI	kPa	Bars	Ft.	M.	GPM	L/M	■	▲	■	▲
360°	30	207	2.07	16	4.87	1.34	5.07	0.50	0.58	12.70	14.73
	35	241	2.41	17	5.18	1.50	5.68	0.50	0.58	12.70	14.73
	40	276	2.76	18	5.48	1.65	6.24	0.49	0.57	12.44	14.48
	45	310	3.10	19	5.79	1.68	6.36	0.50	0.58	12.70	14.73
	50	345	3.45	19	5.79	1.88	7.11	0.56	0.64	14.22	16.25



RN300-ADJ-90-270 (MEDIUM GREY)

ARC	PRESSURE			RADIUS		FLOW RATE		PRECIP in/hr		PRECIP mm/hr	
	PSI	kPa	Bars	Ft.	M.	GPM	L/M	■	▲	■	▲
90°	30	207	2.07	26	7.92	0.80	3.03	0.44	0.51	11.17	12.95
	35	241	2.41	26	7.92	0.85	3.22	0.46	0.53	11.68	12.46
	40	276	2.76	27	8.23	0.90	3.40	0.46	0.53	11.68	12.46
	45	310	3.10	28	8.53	0.95	3.59	0.44	0.50	11.17	12.70
	50	345	3.45	28	8.53	1.00	3.78	0.45	0.52	11.43	13.21
180°	30	207	2.07	26	7.92	1.40	5.30	0.44	0.51	11.17	12.95
	35	241	2.41	27	8.23	1.50	5.68	0.42	0.49	10.67	12.44
	40	276	2.76	27	8.23	1.60	6.05	0.46	0.53	11.68	12.46
	45	310	3.10	29	8.84	1.70	6.43	0.41	0.47	10.41	11.94
	50	345	3.45	30	9.14	1.80	6.81	0.40	0.46	10.16	11.68
270°	30	207	2.07	26	7.92	2.45	9.27	0.44	0.51	11.17	12.95
	35	241	2.41	27	8.23	2.55	9.65	0.42	0.49	10.67	12.44
	40	276	2.76	28	8.53	2.75	10.41	0.43	0.50	10.92	12.70
	45	310	3.10	28	8.53	2.90	10.98	0.44	0.50	11.17	12.70
	50	345	3.45	27	8.23	3.10	11.73	0.49	0.56	12.44	14.22

RN300-FIX360 (LIGHT GREY)

ARC	PRESSURE			RADIUS		FLOW RATE		PRECIP in/hr		PRECIP mm/hr	
	PSI	kPa	Bars	Ft.	M.	GPM	L/M	■	▲	■	▲
360°	30	207	2.07	26	7.92	3.10	11.73	0.44	0.51	11.17	12.95
	35	241	2.41	27	8.23	3.20	12.11	0.42	0.49	10.67	12.44
	40	276	2.76	28	8.53	3.50	13.25	0.43	0.50	10.92	12.70
	45	310	3.10	28	8.53	3.55	13.43	0.44	0.50	11.17	12.70
	50	345	3.45	30	9.1	3.70	14.00	0.42	0.49	10.67	12.44

Performance Data - Special Patterns

PATTERN	NOZZLE	PRESSURE			WIDTH X LENGTH		FLOW RATE	
		PSI	kPa	Bars	Feet	Meters	GPM	L/M
Right End Strip 	RNS-RES-515 Burnt Orange	30	206	2.06	4 x 15	1.22 x 4.6	0.30	1.14
		35	246	2.46	5 x 15	1.5 x 4.6	0.32	1.21
		40	275	2.75	5 x 15	1.5 x 4.6	0.35	1.32
		45	310	3.10	6 x 16	1.8 x 4.9	0.38	1.43
		50	345	3.45	6 x 16	1.8 x 4.9	0.40	1.51
Left End Strip 	RNS-LES-515 Olive	30	206	2.06	4 x 15	1.22 x 4.6	0.30	1.14
		35	246	2.46	5 x 15	1.5 x 4.6	0.32	1.21
		40	275	2.75	5 x 15	1.5 x 4.6	0.35	1.32
		45	310	3.10	6 x 15	1.8 x 4.6	0.38	1.43
		50	345	3.45	6 x 16	1.8 x 4.9	0.40	1.51
Side Strip 	RNS-SS-530 Brown	30	206	2.06	4 x 29	1.22 x 8.8	0.50	1.80
		35	246	2.46	5 x 30	1.5 x 9.1	0.55	2.08
		40	275	2.75	5 x 30	1.5 x 9.1	0.60	2.30
		45	310	3.10	6 x 31	1.8 x 9.4	0.65	2.46
		50	345	3.45	7 x 32	2.1 x 9.7	0.70	2.64

*Data represents test results in zero wind. Adjust for local conditions. Radius may be reduced with the nozzle retention screw.



HE KVF NOZZLES

High Efficiency Nozzles

Application: Residential / Light Commercial

K-Rain's High Efficiency KVF nozzles bring complete flexibility to contractors working with sprays in a variety of terrains. The fully adjustable, female threaded nozzles fit the K-Rain Pro-S series and the NP spray bodies, as well as any other male threaded spray body on the market.

Choose from 8', 10', 12', 15' and 17' configurations.



Models

- KVF-8 8' Nozzle, Green
- KVF-10 10' Nozzle, Blue
- KVF-12 12' Nozzle, Brown
- KVF-15 15' Nozzle, Black
- KVF-17 17' Nozzle, Grey

Performance Data

KVF-8 8' NOZZLE (GREEN)

ARC	PRESSURE			RADIUS		FLOW RATE			PRECIP in/hr		PRECIP mm/hr	
	PSI	kPa	Bars	Ft.	M.	GPM	L/M	M ³ /H	■	▲	■	▲
90°	20	138	1.38	6'	1.8	0.28	1.05	0.06	1.66	1.91	42	49
	25	207	2.07	7'	2.1	0.30	1.14	0.07	1.81	2.09	46	53
	30	276	2.76	8'	2.4	0.31	1.17	0.07	1.87	2.15	47	55
	40	345	3.45	8'	2.4	0.37	1.40	0.08	2.20	2.54	56	65
180°	20	138	1.38	7'	2.1	0.55	2.08	0.12	1.66	1.91	42	49
	25	207	2.07	7'	2.1	0.60	2.27	0.14	1.81	2.09	46	53
	30	276	2.76	8'	2.4	0.62	2.34	0.14	1.87	2.15	47	55
	40	345	3.45	9'	2.7	0.73	2.76	0.17	2.20	2.54	56	65
270°	20	138	1.38	8'	2.4	0.83	3.14	0.19	1.66	1.91	42	49
	25	207	2.07	8'	2.4	0.90	3.41	0.20	1.81	2.09	46	53
	30	276	2.76	9'	2.7	0.93	3.52	0.21	1.87	2.15	47	55
	40	345	3.45	10'	3.0	1.10	4.16	0.25	2.20	2.54	56	65
360°	20	138	1.38	8'	2.4	1.10	4.16	0.25	1.66	1.91	42	49
	25	207	2.07	9'	2.7	1.20	4.54	0.27	1.81	2.09	46	53
	30	276	2.76	10'	3.0	1.24	4.69	0.28	1.87	2.15	47	55
	40	345	3.45	11'	3.4	1.46	5.53	0.33	2.20	2.54	56	65

KVF-10 10' NOZZLE (BLUE)

ARC	PRESSURE			RADIUS		FLOW RATE			PRECIP in/hr		PRECIP mm/hr	
	PSI	kPa	Bars	Ft.	M.	GPM	L/M	M ³ /H	■	▲	■	▲
90°	20	138	1.38	9'	2.7	0.43	1.63	0.10	1.66	1.91	42	49
	25	207	2.07	9'	2.7	0.47	1.78	0.11	1.79	2.07	45	53
	30	276	2.76	10'	3.0	0.52	2.00	0.12	2.00	2.31	51	59
	40	345	3.45	11'	3.4	0.60	2.27	0.14	2.31	2.67	59	68
180°	20	138	1.38	9'	2.7	0.86	3.25	0.20	1.66	1.91	42	49
	25	207	2.07	10'	3.0	0.93	3.52	0.21	1.79	2.07	45	53
	30	276	2.76	11'	3.4	1.04	3.93	0.24	2.00	2.31	51	59
	40	345	3.45	12'	3.7	1.20	4.54	0.27	2.31	2.67	59	68
270°	20	138	1.38	10'	3.0	1.29	4.88	0.29	1.66	1.91	42	49
	25	207	2.07	10'	3.0	1.40	5.30	0.32	1.79	2.07	45	53
	30	276	2.76	11'	3.4	1.56	5.90	0.35	2.00	2.31	51	59
	40	345	3.45	12'	3.7	1.80	6.81	0.41	2.31	2.67	59	68
360°	20	138	1.38	9'	2.7	1.72	6.51	0.39	1.66	1.91	42	49
	25	207	2.07	10'	3.0	1.86	7.04	0.42	1.79	2.07	45	53
	30	276	2.76	11'	3.4	2.08	7.87	0.47	2.00	2.31	51	59
	40	345	3.45	12'	3.7	2.40	9.08	0.54	2.31	2.67	59	68

*Data represents test results in zero wind. Adjust for local conditions. Radius may be reduced with the nozzle retention screw. Bold = recommended pressure.



Features and Benefits

- Superior Spray Patterns
- Color-coded for Easy Identification
- Uniform Water Distribution
- Water Efficient Low Flow Rates
- Extra Long Filters Extend Time Between Cleanings

Performance Data (con't)

KVF-12 12' NOZZLE (BROWN)

ARC	PRESSURE			RADIUS		FLOW RATE			PRECIP in/hr		PRECIP mm/hr	
	PSI	kPa	Bars	Ft.	M.	GPM	L/M	M ³ /H	■	▲	■	▲
90°	20	138	1.38	11'	3.4	0.49	1.85	0.11	1.54	1.50	33	38
	25	207	2.07	12'	3.7	0.51	1.93	0.12	1.36	1.58	35	40
	30	276	2.76	12'	3.7	0.60	2.27	0.14	1.61	1.85	41	47
	40	345	3.45	13'	4.0	0.65	2.46	0.15	1.48	2.01	44	51
180°	20	138	1.38	11'	3.4	0.94	3.67	0.22	1.54	1.50	33	38
	25	207	2.07	11'	3.4	1.02	3.86	0.23	1.36	1.58	35	40
	30	276	2.76	12'	3.7	1.20	4.54	0.27	1.61	1.85	41	47
	40	345	3.45	13'	4.0	1.30	4.92	0.30	1.54	1.50	44	51
270°	20	138	1.38	10'	3.0	1.46	5.53	0.33	1.54	1.50	33	38
	25	207	2.07	11'	3.4	1.53	5.79	0.35	1.36	1.58	35	40
	30	276	2.76	12'	3.7	1.80	6.81	0.41	1.61	1.85	41	47
	40	345	3.45	13'	4.0	1.95	7.38	0.44	1.54	1.50	44	51
360°	20	138	1.38	10'	3.0	1.94	7.34	0.44	1.54	1.50	33	38
	25	207	2.07	11'	3.4	2.04	7.72	0.46	1.36	1.58	35	40
	30	276	2.76	12'	3.7	2.40	9.08	0.54	1.61	1.85	41	47
	40	345	3.45	13'	4.0	2.60	9.84	0.59	1.54	1.50	44	51

KVF-15 15' NOZZLE (BLACK)

ARC	PRESSURE			RADIUS		FLOW RATE			PRECIP in/hr		PRECIP mm/hr	
	PSI	kPa	Bars	Ft.	M.	GPM	L/M	M ³ /H	■	▲	■	▲
90°	20	138	1.38	15'	4.6	0.75	2.84	0.17	1.28	1.48	33	38
	25	207	2.07	16'	4.9	0.80	3.03	0.18	1.37	1.58	35	40
	30	276	2.76	17'	5.2	0.88	3.33	0.20	1.50	1.73	38	44
	40	345	3.45	17'	5.2	1.00	3.79	0.23	1.71	1.98	43	50
180°	20	138	1.38	13'	4.0	1.50	5.68	0.34	1.28	1.48	33	38
	25	207	2.07	14'	4.3	1.60	6.06	0.36	1.37	1.58	35	40
	30	276	2.76	15'	4.6	1.75	6.62	0.40	1.50	1.73	38	44
	40	345	3.45	15'	4.6	2.00	7.57	0.45	1.71	1.98	43	50
270°	20	138	1.38	13'	4.0	2.25	8.52	0.51	1.28	1.48	33	38
	25	207	2.07	14'	4.3	2.40	9.08	0.54	1.37	1.58	35	40
	30	276	2.76	15'	4.6	2.63	9.96	0.60	1.50	1.73	38	44
	40	345	3.45	15'	4.6	3.00	11.36	0.68	1.71	1.98	43	50
360°	20	138	1.38	13'	4.0	3.00	11.36	0.68	1.28	1.48	33	38
	25	207	2.07	14'	4.3	3.20	12.11	0.73	1.37	1.58	35	40
	30	276	2.76	15'	4.6	3.50	13.25	0.80	1.50	1.73	38	44
	40	345	3.45	15'	4.6	4.00	15.41	0.91	1.71	1.98	43	50

KVF-17 17' NOZZLE (GREY)

ARC	PRESSURE			RADIUS		FLOW RATE			PRECIP in/hr		PRECIP mm/hr	
	PSI	kPa	Bars	Ft.	M.	GPM	L/M	M ³ /H	■	▲	■	▲
90°	20	138	1.38	16'	4.9	0.93	3.52	0.21	1.23	1.42	31	36
	25	207	2.07	17'	5.2	1.00	3.79	0.23	1.33	1.54	34	39
	30	276	2.76	18'	5.5	1.10	4.16	0.25	1.47	1.69	37	43
	40	345	3.45	19'	5.8	1.25	4.73	0.28	1.67	1.92	42	49
180°	20	138	1.38	15'	4.6	1.85	7.00	0.42	1.23	1.42	31	36
	25	207	2.07	16'	4.9	2.00	7.57	0.45	1.33	1.54	34	39
	30	276	2.76	17'	5.2	2.20	8.32	0.50	1.47	1.69	37	43
	40	345	3.45	18'	5.5	2.50	9.46	0.57	1.67	1.92	42	49
270°	20	138	1.38	14'	4.3	2.78	10.52	0.63	1.23	1.42	31	36
	25	207	2.07	15'	4.6	3.00	11.36	0.68	1.33	1.54	34	39
	30	276	2.76	16'	4.9	3.30	12.49	0.75	1.47	1.69	37	43
	40	345	3.45	17'	5.2	3.75	14.20	0.85	1.67	1.92	42	49
360°	20	138	1.38	14'	4.3	3.70	14.01	0.84	1.23	1.42	31	36
	25	207	2.07	15'	4.6	4.00	15.14	0.91	1.33	1.54	34	39
	30	276	2.76	16'	4.9	4.40	16.66	1.00	1.47	1.69	37	43
	40	345	3.45	17'	5.2	5.00	18.93	1.14	1.67	1.92	42	49

*Data represents test results in zero wind. Adjust for local conditions. Radius may be reduced with the nozzle retention screw. Bold = recommended pressure.

KV NOZZLES

Adjustable Pattern Male Thread Nozzles

Application: Residential / Light Commercial

K-Rain's KV Adjustable Nozzles have a superior spray pattern that ensures proper precipitation rates throughout the adjustment.

They have a male thread configuration to fit K-Rain K-Spray bodies. Extra long filters provide longer time between cleanings.



Models

- KV-8 8' Spray, Green
- KV-10 10' Spray, Blue
- KV-12 12' Spray, Brown
- KV-15 15' Spray, Black
- KV-17 17' Spray, Grey



Performance Data

KV-8 8' NOZZLE (GREEN)

ARC	PRESSURE			RADIUS		FLOW RATE			PRECIP in/hr		PRECIP mm/hr	
	PSI	kPa	Bars	Ft.	M.	GPM	L/M	M ³ /H	■	▲	■	▲
90°	20	138	1.38	7'	2.1	0.3	1.2	0.07	2.51	2.90	64	74
	30	207	2.07	8'	2.4	0.4	1.3	0.08	2.11	2.43	53	62
	40	276	2.76	8'	2.4	0.4	1.5	0.09	2.35	2.71	60	69
	50	345	3.45	9'	2.7	0.4	1.6	0.10	2.00	2.31	51	59
180°	20	138	1.38	7'	2.1	0.8	3.0	0.18	3.14	3.63	80	92
	30	207	2.07	8'	2.4	0.9	3.4	0.20	2.71	3.13	69	79
	40	276	2.76	8'	2.4	1.0	3.7	0.22	2.95	3.14	75	86
	50	345	3.45	9'	2.7	1.1	4.0	0.24	2.50	2.88	63	73
270°	20	138	1.38	7'	2.1	1.2	4.4	0.26	3.06	3.54	78	90
	30	207	2.07	8'	2.4	1.2	4.7	0.28	2.49	2.87	63	73
	40	276	2.76	8'	2.4	1.3	5.0	0.30	2.63	3.03	67	77
	50	345	3.45	9'	2.7	1.5	5.8	0.35	2.42	2.80	62	71
360°	20	138	1.38	7'	2.1	1.9	7.0	0.42	3.65	4.22	93	107
	30	207	2.07	8'	2.4	2.0	7.7	0.46	3.05	3.53	78	90
	40	276	2.76	8'	2.7	2.2	8.3	0.50	3.29	3.80	84	97
	50	345	3.45	9'	2.7	2.3	8.7	0.52	2.73	3.16	69	80

KV-10 10' NOZZLE (BLUE)

ARC	PRESSURE			RADIUS		FLOW RATE			PRECIP in/hr		PRECIP mm/hr	
	PSI	kPa	Bars	Ft.	M.	GPM	L/M	M ³ /H	■	▲	■	▲
90°	20	138	1.38	12'	3.7	0.7	2.6	0.16	1.87	2.90	48	55
	30	207	2.07	12'	3.7	1.1	4.0	0.24	2.94	2.43	75	86
	40	276	2.76	13'	4.0	1.4	5.3	0.32	3.19	2.71	81	94
	50	345	3.45	14'	4.3	1.5	5.7	0.34	2.95	2.31	75	86
180°	20	138	1.38	11'	3.4	1.4	5.3	0.32	3.14	2.23	57	65
	30	207	2.07	11'	3.4	1.6	6.1	0.37	2.71	2.55	65	75
	40	276	2.76	12'	3.7	1.8	6.8	0.41	2.95	2.41	61	71
	50	345	3.45	13'	4.0	2.0	7.6	0.46	2.50	2.28	58	67
270°	20	138	1.38	10'	3.0	1.7	6.4	0.38	3.06	2.18	55	64
	30	207	2.07	10'	3.0	2.0	7.6	0.46	2.49	2.57	65	75
	40	276	2.76	11'	3.4	2.3	8.7	0.52	2.63	2.44	62	72
	50	345	3.45	12'	3.7	2.6	9.8	0.59	2.42	2.32	59	68
360°	20	138	1.38	10'	3.0	2.2	8.3	0.50	3.65	2.12	54	62
	30	207	2.07	10'	3.0	2.7	10.2	0.61	3.05	2.60	66	76
	40	276	2.76	11'	3.4	3.0	11.4	0.68	3.29	2.39	61	70
	50	345	3.45	12'	3.7	3.5	13.2	0.79	2.73	2.34	59	69

*Data represents test results in zero wind. Adjust for local conditions. Radius may be reduced with the nozzle retention screw.



Performance Data (con't)

KV-12 12' NOZZLE (BROWN)

ARC	PRESSURE			RADIUS		FLOW RATE			PRECIP in/hr		PRECIP mm/hr	
	PSI	kPa	Bars	Ft.	M.	GPM	L/M	M ³ /H	■	▲	■	▲
90°	20	138	1.38	12'	3.7	1.1	4.2	0.25	2.94	3.40	75	86
	30	207	2.07	13'	4.0	1.3	4.9	0.29	2.96	3.42	75	87
	40	276	2.76	14'	4.3	1.5	5.7	0.34	2.95	3.40	75	86
	50	345	3.45	15'	4.6	1.7	6.4	0.38	2.91	3.36	74	85
180°	20	138	1.38	11'	3.4	1.6	6.1	0.37	2.55	2.94	65	75
	30	207	2.07	12'	3.7	1.8	6.8	0.41	2.41	2.78	61	71
	40	276	2.76	13'	4.0	2.2	8.3	0.50	2.51	2.89	64	73
	50	345	3.45	14'	4.3	2.4	9.1	0.55	2.36	2.72	60	69
270°	20	138	1.38	11'	3.4	1.9	7.2	0.43	2.02	2.33	51	59
	30	207	2.07	12'	3.7	2.4	9.1	0.55	2.14	2.47	54	63
	40	276	2.76	12'	3.7	2.6	9.8	0.59	2.32	2.68	59	68
	50	345	3.45	13'	4.0	3.2	11.4	0.68	2.28	2.63	58	67
360°	20	138	1.38	11'	3.4	2.8	10.6	0.64	2.23	2.57	57	65
	30	207	2.07	12'	3.7	3.1	11.7	0.70	2.07	2.39	53	61
	40	276	2.76	12'	3.7	3.5	13.2	0.79	2.34	2.70	59	69
	50	345	3.45	13'	4.0	3.9	14.8	0.89	2.22	2.56	56	65

KV-15 15' NOZZLE (BLACK)

ARC	PRESSURE			RADIUS		FLOW RATE			PRECIP in/hr		PRECIP mm/hr	
	PSI	kPa	Bars	Ft.	M.	GPM	L/M	M ³ /H	■	▲	■	▲
90°	20	138	1.38	15'	4.6	1.3	4.9	0.29	2.22	2.57	57	65
	30	207	2.07	17'	5.2	1.6	6.1	0.37	2.13	2.46	54	63
	40	276	2.76	18'	5.5	1.8	6.8	0.41	2.14	2.47	54	63
	50	345	3.45	19'	5.8	2.0	7.5	0.46	2.13	2.46	54	63
180°	20	138	1.38	14'	4.3	1.8	6.8	0.41	1.77	2.04	45	52
	30	207	2.07	15'	4.6	2.3	8.7	0.52	1.97	2.27	50	58
	40	276	2.76	16'	4.9	2.6	9.8	0.59	1.96	2.26	50	57
	50	345	3.45	18'	5.5	2.8	10.6	0.64	1.66	1.92	42	49
270°	20	138	1.38	14'	4.3	2.7	10.2	0.61	1.77	2.04	45	52
	30	207	2.07	15'	4.6	3.2	12.1	0.73	1.83	2.11	46	54
	40	276	2.76	16'	4.9	3.6	13.6	0.82	1.80	2.08	46	53
	50	345	3.45	18'	4.9	4.0	15.1	0.91	1.58	1.83	40	46
360°	20	138	1.38	14'	4.0	3.4	12.9	0.77	1.67	1.93	42	49
	30	207	2.07	15'	4.6	4.2	15.9	0.95	1.80	2.07	46	53
	40	276	2.76	16'	4.6	4.7	17.8	1.07	1.77	2.04	45	52
	50	345	3.45	16'	4.9	5.3	20.1	1.21	1.99	2.30	51	58

KV-17 17' NOZZLE (GREY)

ARC	PRESSURE			RADIUS		FLOW RATE			PRECIP in/hr		PRECIP mm/hr	
	PSI	kPa	Bars	Ft.	M.	GPM	L/M	M ³ /H	■	▲	■	▲
90°	20	138	1.38	18'	4.6	1.7	4.9	0.29	2.02	2.33	51	59
	30	207	2.07	18'	5.5	1.8	6.8	0.41	2.14	2.47	54	63
	40	276	2.76	19'	5.8	2.0	7.6	0.46	2.13	2.46	54	63
	50	345	3.45	20'	6.1	2.2	8.3	0.50	2.12	2.45	54	62
180°	20	138	1.38	17'	5.2	1.9	7.2	0.43	1.27	1.46	32	37
	30	207	2.07	18'	5.5	2.4	9.1	0.55	1.43	1.65	36	42
	40	276	2.76	19'	5.8	2.6	9.8	0.59	1.39	1.60	35	41
	50	345	3.45	19'	5.8	2.9	11.0	0.66	1.55	1.79	39	45
270°	20	138	1.38	16'	4.9	2.9	11.0	0.66	1.45	1.68	37	43
	30	207	2.07	17'	5.2	3.4	12.9	0.77	1.51	1.74	38	44
	40	276	2.76	18'	5.5	4.0	15.1	0.91	1.58	1.83	40	46
	50	345	3.45	18'	5.5	4.5	17.0	1.02	1.78	2.06	45	52
360°	20	138	1.38	15'	4.6	3.5	13.2	0.79	1.50	1.73	38	44
	30	207	2.07	17'	5.2	4.4	16.7	1.00	1.47	1.69	37	43
	40	276	2.76	17'	5.2	4.9	18.5	1.11	1.63	1.88	41	48
	50	345	3.45	18'	5.5	5.4	20.4	1.22	1.60	1.85	41	47

*Data represents test results in zero wind. Adjust for local conditions. Radius may be reduced with the nozzle retention screw.

KV Nozzles' extra long filters provide longer time between cleanings.

FIXED NOZZLES

Fixed Pattern Nozzles

Application: Residential / Light Commercial

K-Rain's Fixed Pattern Nozzles provide matched precipitation for even water distribution.







Models





- FN-8** 8' Female Nozzle, Green
- FN-10** 10' Female Nozzle, Blue
- FN-12** 12' Female Nozzle, Brown
- FN-15** 15' Female Nozzle, Black
- P-12** 12' Male Nozzle, Brown
- P-15** 15' Male Nozzle, Black
- CS** Center Strip
- ES** End Strip
- SS** Side Strip
- HL** High Low

Performance Data - Male Threaded Nozzles





FN-12 12' MALE THREADED NOZZLE (BROWN)

NOZZLE/ PATTERN	PRESSURE			RADIUS		FLOW RATE			PRECIP in/hr		PRECIP mm/hr	
	PSI	kPa	Bars	Ft.	M.	GPM	L/M	M ³ /H	■	▲	■	▲
P12Q 90° 	20	150	1.5	11'	3.4	0.50	1.9	0.11	1.59	1.84	40	47
	25	200	2.0	12'	3.7	0.70	2.9	0.16	1.87	2.16	48	55
	40	300	3.0	13'	4.0	0.80	3.0	0.18	1.82	2.10	46	53
	50	350	3.5	14'	4.3	0.90	3.4	0.20	1.77	2.04	45	52
P12H 180° 	20	150	1.5	11'	3.4	0.90	3.4	0.20	1.43	1.65	36	42
	25	200	2.0	12'	3.7	1.10	4.2	0.25	1.47	1.70	37	43
	40	300	3.0	13'	4.0	1.40	5.3	0.32	1.59	1.84	41	47
	50	350	3.5	14'	4.3	1.50	5.7	0.34	1.47	1.70	37	43
P12TQ 270° 	20	150	1.5	11'	3.4	1.20	4.5	0.27	1.27	1.47	32	37
	25	200	2.0	12'	3.7	1.40	5.3	0.32	1.25	1.44	32	37
	40	300	3.0	13'	4.0	1.70	6.4	0.38	1.29	1.49	33	38
	50	350	3.5	14'	4.3	2.00	7.6	0.46	1.31	1.51	33	38
P12F 360° 	20	150	1.5	11'	3.4	1.60	6.1	0.37	1.27	1.47	32	37
	25	200	2.0	12'	3.7	1.80	6.8	0.41	1.20	1.39	31	35
	40	300	3.0	13'	4.0	2.10	7.9	0.47	1.20	1.38	30	35
	50	350	3.5	14'	4.3	2.40	9.1	0.55	1.18	1.36	30	35

FN-15 15' MALE THREADED NOZZLE (BLACK)

NOZZLE/ PATTERN	PRESSURE			RADIUS		FLOW RATE			PRECIP in/hr		PRECIP mm/hr	
	PSI	kPa	Bars	Ft.	M.	GPM	L/M	M ³ /H	■	▲	■	▲
P15Q 90° 	20	150	1.5	15'	4.6	0.70	2.6	0.16	1.20	1.38	30	35
	25	200	2.0	16'	4.9	0.90	3.4	0.20	1.35	1.56	34	40
	40	300	3.0	17'	5.2	1.10	4.2	0.25	1.43	1.69	37	43
	50	350	3.5	18'	5.5	1.20	4.5	0.27	1.43	1.65	36	42
P15H 180° 	20	150	1.5	15'	4.6	1.40	5.3	0.32	1.20	1.38	30	35
	25	200	2.0	16'	4.9	1.70	6.4	0.38	1.28	1.48	32	37
	40	300	3.0	17'	5.2	2.00	7.6	0.46	1.33	1.54	34	39
	50	350	3.5	18'	5.5	2.20	8.3	0.50	1.31	1.51	33	38
P15TQ 270° 	20	150	1.5	15'	4.6	2.00	7.6	0.46	1.14	1.32	29	33
	25	200	2.0	16'	4.9	2.50	9.5	0.57	1.25	1.45	32	37
	40	300	3.0	17'	5.2	2.90	11.0	0.66	1.29	1.49	33	38
	50	350	3.5	18'	5.5	3.20	12.1	0.73	1.27	1.46	32	37
P15F 360° 	20	150	1.5	15'	4.6	2.90	11.0	0.66	1.24	1.43	32	36
	25	200	2.0	16'	4.9	3.60	13.6	0.82	1.35	1.56	34	40
	40	300	3.0	17'	5.2	4.10	15.5	0.93	1.37	1.58	35	40
	50	350	3.5	18'	5.5	4.60	17.4	1.04	1.37	1.58	35	40

Performance Data - Special Patterns

PATTERN	NOZZLE		PRESSURE			RADIUS		FLOW RATE	
	Male#	Female#	PSI	kPa	Bars	Feet	Meters	GPM	L/M
Center strip 	15CS	FN15CS	20	150	1.5	4' x 24'	1.2 x 7.3	0.8	3.0
			30	200	2.0	4' x 30'	1.2 x 9.1	1.0	3.8
End Strip 	15ES	FN15ES	20	150	1.5	4' x 12'	1.2 x 7.3	0.4	1.5
			30	200	2.0	4' x 15'	1.2 x 4.6	0.5	1.9
Side Strip 	15SS	FN15SS	20	150	1.5	4' x 28'	1.2 x 8.5	1.1	4.2
			30	200	2.0	5' x 32'	1.5 x 9.8	1.3	4.9
High Low 	15HL	FN15HL	20	150	1.5	H14' x L4' x 28'	4.3 x 1.2 x 8.5	2.5	9.5
			30	200	2.0	H15' x L5' x 32'	4.6 x 1.5 x 9.8	3.0	11.4





*Data represents test results in zero wind. Adjust for local conditions. Radius may be reduced with the nozzle retention screw.







Performance Data - Female Threaded Nozzles

FN-8 8' FEMALE THREADED NOZZLE (GREEN)





Female nozzles are compatible with all available male threaded spray bodies. Available in four distances plus eight fixed patterns, providing an array of system configurations. Color-coded for easy identification.

NOZZLE/ PATTERN	PRESSURE			RADIUS		FLOW RATE			PRECIP in/hr		PRECIP mm/hr	
	PSI	kPa	Bars	Ft.	M.	GPM	L/M	M ³ /H	■	▲	■	▲
FN8Q 90° 	15	100	1.0	5'	1.7	0.18	0.7	0.04	—	3.20	—	81
	20	150	1.5	6'	2.1	0.21	0.8	0.05	2.25	2.59	57	66
	25	200	2.0	7'	2.4	0.24	0.9	0.05	1.89	2.18	48	55
	30	210	2.1	8'	2.4	0.26	1.0	0.06	1.56	1.81	40	46
FN8H 180° 	15	100	1.0	5'	1.7	0.37	1.4	0.08	2.85	3.29	72	84
	20	150	1.5	6'	2.1	0.42	1.6	0.10	2.25	2.59	57	66
	25	200	2.0	7'	2.4	0.47	1.8	0.11	1.85	2.13	47	54
	30	210	2.1	8'	2.4	0.52	2.0	0.12	1.56	1.81	40	46
FN8TQ 270° 	15	100	1.0	5'	1.7	0.55	2.1	0.13	2.82	3.26	72	83
	20	150	1.5	6'	2.1	0.63	2.4	0.14	2.25	2.59	57	66
	25	200	2.0	7'	2.4	0.71	2.7	0.16	1.86	2.15	47	55
	30	210	2.1	8'	2.4	0.78	3.0	0.18	1.56	1.81	40	46
FN8F 360° 	15	100	1.0	5'	1.7	0.74	2.8	0.17	2.85	3.29	72	84
	20	150	1.5	6'	2.1	0.86	3.3	0.20	2.30	2.66	58	67
	25	200	2.0	7'	2.4	0.96	3.6	0.22	1.89	2.18	48	55
	30	210	2.1	8'	2.4	1.05	4.0	0.24	1.58	1.82	40	46





FN-10 10' FEMALE THREADED NOZZLE (BLUE)

NOZZLE/ PATTERN	PRESSURE			RADIUS		FLOW RATE			PRECIP in/hr		PRECIP mm/hr	
	PSI	kPa	Bars	Ft.	M.	GPM	L/M	M ³ /H	■	▲	■	▲
FN10Q 90° 	15	100	1.0	7'	2.1	0.29	1.1	0.07	2.28	2.63	58	67
	20	150	1.5	8'	2.4	0.33	1.2	0.07	1.99	2.29	50	58
	25	200	2.0	9'	3.0	0.36	1.4	0.08	1.71	1.98	43	50
	30	210	2.1	10'	3.1	0.39	1.5	0.09	1.50	1.73	38	44
FN10H 180° 	15	100	1.0	7'	1.7	0.58	2.2	0.13	2.28	2.63	58	67
	20	150	1.5	8'	2.1	0.65	2.5	0.15	1.96	2.26	50	57
	25	200	2.0	9'	2.4	0.72	2.7	0.16	1.71	1.98	43	50
	30	210	2.1	10'	2.4	0.79	3.0	0.18	1.52	1.76	39	45
FN10TQ 270° 	15	100	1.0	7'	1.7	0.87	3.3	0.20	2.28	2.63	58	67
	20	150	1.5	8'	2.1	0.98	3.7	0.22	1.97	2.27	50	58
	25	200	2.0	9'	2.4	1.08	4.1	0.25	1.71	1.98	43	50
	30	210	2.1	10'	2.4	1.18	4.5	0.27	1.51	1.75	38	44
FN10F 360° 	15	100	1.0	7'	1.7	1.16	4.4	0.26	2.28	2.63	58	67
	20	150	1.5	8'	2.1	1.03	4.9	0.29	1.96	2.26	50	57
	25	200	2.0	9'	2.4	1.44	5.5	0.33	1.71	1.98	43	50
	30	210	2.1	10'	2.4	1.58	6.0	0.36	1.52	1.76	39	45

FN-12 12' FEMALE THREADED NOZZLE (BROWN)

NOZZLE/ PATTERN	PRESSURE			RADIUS		FLOW RATE			PRECIP in/hr		PRECIP mm/hr	
	PSI	kPa	Bars	Ft.	M.	GPM	L/M	M ³ /H	■	▲	■	▲
FN12Q 90° 	15	100	1.0	9'	2.7	0.45	1.7	0.10	2.14	2.47	54	63
	20	150	1.5	10'	3.2	0.53	2.0	0.12	2.04	2.36	52	60
	25	200	2.0	11'	3.6	0.60	2.3	0.14	1.91	2.20	48	56
	30	210	2.1	12'	3.7	0.65	2.5	0.15	1.74	2.01	44	51
FN12H 180° 	15	100	1.0	9'	2.7	0.90	3.4	0.20	2.14	2.47	54	63
	20	150	1.5	10'	3.2	1.05	4.0	0.24	2.02	2.33	51	59
	25	200	2.0	11'	3.6	1.20	4.5	0.27	1.91	2.20	48	56
	30	210	2.1	12'	3.7	1.30	4.9	0.29	1.74	2.01	44	51
FN12TQ 270° 	15	100	1.0	9'	2.7	1.35	5.1	0.31	2.14	2.47	54	63
	20	150	1.5	10'	3.2	1.58	6.0	0.36	2.03	2.34	52	59
	25	200	2.0	11'	3.6	1.80	6.8	0.41	1.91	2.20	48	56
	30	210	2.1	12'	3.7	1.95	7.4	0.44	1.74	2.01	44	51
FN12F 360° 	15	100	1.0	9'	2.7	1.80	6.8	0.41	2.14	2.47	54	63
	20	150	1.5	10'	3.2	2.10	7.9	0.47	2.02	2.33	51	59
	25	200	2.0	11'	3.6	2.40	9.1	0.55	1.91	2.20	48	56
	30	210	2.1	12'	3.7	2.60	9.8	0.59	1.74	2.01	44	51

FN-15 15' FEMALE THREADED NOZZLE (BLACK)

NOZZLE/ PATTERN	PRESSURE			RADIUS		FLOW RATE			PRECIP in/hr		PRECIP mm/hr	
	PSI	kPa	Bars	Ft.	M.	GPM	L/M	M ³ /H	■	▲	■	▲
FN15Q 90° 	15	100	1.0	11'	3.4	0.65	2.5	0.15	2.07	2.39	53	61
	20	150	1.5	12'	3.9	0.75	2.8	0.17	2.01	2.32	51	59
	25	200	2.0	14'	4.5	0.82	3.1	0.19	1.61	1.86	41	47
	30	210	2.1	15'	4.6	0.92	3.5	0.21	1.57	1.82	40	46
FN15H 180° 	15	100	1.0	11'	3.4	1.30	4.9	0.29	2.07	2.39	53	61
	20	150	1.5	12'	3.9	1.50	5.7	0.34	2.01	2.32	51	59
	25	200	2.0	14'	4.5	1.65	6.2	0.37	1.62	1.87	41	48
	30	210	2.1	15'	4.6	1.85	7.0	0.42	1.58	1.83	40	46
FN15TQ 270° 	15	100	1.0	11'	3.4	1.95	7.4	0.44	2.07	2.39	53	61
	20	150	1.5	12'	3.9	2.25	8.6	0.52	2.01	2.32	51	59
	25	200	2.0	14'	4.5	2.48	9.4	0.56	1.62	1.88	41	48
	30	210	2.1	15'	4.6	2.78	10.6	0.64	1.59	1.83	40	47
FN15F 360° 	15	100	1.0	11'	3.4	2.60	9.8	0.59	2.07	2.39	53	61
	20	150	1.5	12'	3.9	3.00	11.4	0.68	2.01	2.32	51	59
	25	200	2.0	14'	4.5	3.30	12.5	0.75	1.62	1.87	41	48
	30	210	2.1	15'	4.6	3.70	14.0	0.84	1.58	1.83	40	46

*Data represents test results in zero wind. Adjust for local conditions. Radius may be reduced with the nozzle retention screw.

TREE BUBBLERS

Pressure Compensating Tree Bubblers

Application: Non-turf Areas

K-Rain's pressure compensating bubblers release water at a slower rate than conventional sprays, maintaining even flow and reducing runoff. Perfect for controlled, gentle irrigation of trees and shrub areas. Low flow rates allow water to be absorbed slowly.



Models

TB-05	0.5 GPM Bubbler
TB-10	1.0 GPM Bubbler
TB-20	2.0 GPM Bubbler
TB-ADJ	Adjustable Bubbler

Specifications

- Flow Rate:
 - TB-05: 0.5 GPM (0.114 m³/h; 1.9 l/m)
 - TB-10: 1.0 GPM (0.227 m³/h; 3.8 l/m)
 - TB-20: 2.0 GPM (0.454 m³/h; 7.6 l/m)
 - TB-ADJ: 1.36 – 5.9 GPM (0.31 – 1.34 m³/h; 5 – 22 l/m)
- Operating Pressure: 20 – 40 PSI (1.4 – 2.8 bar)
- Spacing: 1' – 3' (.3 m – .9 m)
- Inlet: .5" Female Thread
- Umbrella Pattern



The K-Rain Dripline System provides irrigation efficiency and trouble-free operation.

PC DRIPLINE SYSTEM

Application: Non-turf Areas

Drip irrigation uses up to 50% less water than conventional watering methods and applies water at a slower rate to ensure even soil penetration. Properly installed, a dripline system eliminates run-off and overspray common with conventional sprinklers and is an excellent irrigation alternative for non-turf areas such as shrub beds, parking lot medians and ground cover areas.

The durable poly tubing is manufactured with high quality resins which offers stress-cracking resistance, burst strength and flexibility. The check valve feature prevents water from draining at lower elevations along the line and protects each drip emitter from siphoning sediment, small particles and debris at the end of each irrigation cycle.



Features and Benefits

- **Install Above or Below Grade.**
- **Pressure-compensating Emitters** – Ensure uniform output across the entire length of run.
- **In-line Emitter Check Valves** – Prevent drainage from the dripline when water pressure drops below 2.5 PSI, protecting against the siphoning of small sediment and soil particles into the drip emitter, making it ideal for sub-surface installation.
- **Available in Two Flow Rates and a Wide Range of Spacing and Roll Lengths** – Provides maximum design flexibility in a variety of applications.

Specifications

- Flow rates:
.58 GPH (2.3 L/H) color code - orange
1 GPH (3.8 L/H) color code - gray
- Operating pressure: 12 – 50 PSI (.8 – 3.5 BAR)
- Check valve sealing pressure: 2.5 PSI (.17 BAR)
- Check valve opening pressure: 4.3 PSI (.3 BAR)
- Materials: Dow FINGERPRINT™ DFDA-7510 NT linear low-density polyethylene resin
- Dripline color: brown
- Size: 1/2" (.570 ID x .670 OD) (14.5 mm ID x 17 mm OD)
- Spacing: 12" or 18" (30.5 cm or 45.7 cm)
- Available in 100' coils (30 m)
- Minimum bending radius: 1' (.3 m)
- Filter requirement: minimum of 150 mesh

Models

- KA1-118P-CV** 17 mm 1 GPH, 100' CV drip line coil with 18" spacing, brown (.570 OD x .670 ID)
- KA5-112P-CV** 17 mm .58 GPH, 100' CV drip line coil with 12" spacing, brown (.570 OD x .670 ID)
- K15-030** 17 mm barb coupling
- K15-041** 17 mm tee
- K15-042** 17 mm elbow
- K15-043** 17 mm barb x 1/2" NPT Tee
- K15-046** 17 mm barb x 1/2" NPT Adapter
- K18-028** 1/2" Air/Vacuum Relief Valve
- KP11-155** 3/4" plastic filter with 155 m stainless steel screen & flush cap

PROSERIES 100 VALVES

PRESSURE RATING: 20 – 150 PSI
FLOW RANGE: .25 – 35 GPM

Application: Residential / Light Commercial / Dirty Water

This reliable valve offers a straight-through flow pattern that reduces the risk of trapped debris that causes other brands to fail. It has both an internal bleed and external bleed in addition to optional flow control. The inside diameter (ID) is 1" slip and glue or NPT/BSP. The outside diameter (OD) is 1 1/4" slip for added installation flexibility.



Models

7001	1" Female Thread or 1 1/4" Male Slip
7001-SL	1" Female Slip or 1 1/4" Male Slip
7001-BSP	1" Female BSP Thread or 1 1/4" Male Slip
7001-NFC	1" Female Thread or 1 1/4" Male Slip without Flow Control
7001-SL-NFC	1" Female Slip or 1 1/4" Male Slip without Flow Control
7001-BSP-NFC	1" Female BSP Thread or 1 1/4" Male Slip without Flow Control
7001-MXB	1" Male Thread x 1" Barb
7001-MXM	1" Male Thread x 1" Male Barb
7001-MXB-NFC	1" Male Thread x 1" Barb without Flow Control

How to Specify

Model Number	Description
7001	-SL

Features and Benefits

- **Heavy Duty, Corrosion and UV Resistant PVC Construction** – Increases the life of the valve.
- **Combination 1" and 1 1/4"** – Provides the option to increase pipe size to the valve, increasing flow rate.
- **Tilt Diaphragm/Piston Assembly** – Allows for a straight flow path of water, increasing the flow rate while reducing friction loss.
- **Debris Tolerant Design** – Offers flexibility for use in potable or dirty water applications.
- **Manual External Bleed Screw** – Provides for manual operation in system start up.
- **Manual Internal Bleed Through Solenoid** – Permits manual operation without discharging water outside valve.
- **Flow Control with Removable Handle** – Delivers precise flow adjustment to the zone and allows you to remove the handle to prevent tampering (Except NFC).
- **Captured Plunger** – Remove the solenoid without losing the internal plunger.
- **Self Cleaning Metering Screen** – Screen is in turbulent flow of water for self-cleaning action during operation.
- **Five Year Limited Warranty**

Specifications

OPERATING SPECIFICATIONS

- Pressure Rating: 20 – 150 PSI
- Flow Range: .25 – 35 GPM

PROSERIES 100 1" VALVE

Flow Rate - GPM	5	10	15	20	30
PSI Loss	2.2	3.0	3.5	4.0	5.0

Pressure range: 20-150 psi

ELECTRICAL SPECIFICATIONS

- Solenoid: 24 VAC 60 Cycle
- Inrush Current: .43 Amps
- Holding Current: .25 Amps

DIMENSIONS

- Height: 4"
- Width: 3"
- Length: 5-1/4"



The contemporary tilt diaphragm design of the K-Rain ProSeries 100 makes these valves the perfect choice for residential and commercial applications.

FLOW THROUGH

The unique tilted diaphragm creates a better flow path than traditional globe style electric valves by decreasing friction loss and increasing flow rate.



SELF-CLEANING SCREEN

The straight flow path allows debris to move through and the turbulent water flow cleans the diaphragm filter screen. This provides long life in applications using well or lake water.



CAPTURED PLUNGER SOLENOID

K-Rain's solenoid with captured plunger allows for easy removal when servicing without losing internal parts. Epoxy encapsulated solenoid design ensures longevity unlike the competition's overmolded solenoid.



MANUAL FLOW CONTROL

Precisely adjust flow to the zone. Removable handle prevents tampering.



PROSERIES 150 VALVE

Application: Residential / Light Commercial / Dirty Water

PRESSURE RATING: 10 – 150 PSI
FLOW RANGE: .25 – 30 GPM

K-Rain's ProSeries 150 Valves offer the irrigation professional a wide array of features and benefits.

The 1" valve has a removable metering pin and external bleed screw promoting easy maintenance and manual operation.



**Now available
with Flow Control!**

Manual External Bleed Screw

The 1", 1 1/2" and 2" models feature a removable external bleed screw and metering pin to simplify cleaning and maintenance. With the External Bleed Screw, manual operation during start up is easy.

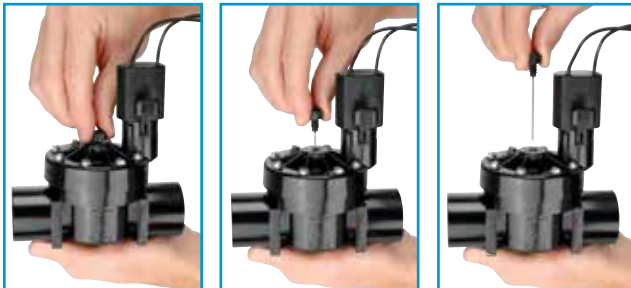

How to Specify

Model Number	Description
7101	-BSP

Features and Benefits

- **Heavy Duty, Corrosion and UV Resistant PVC Construction** – Increases the life of the valve.
- **External Bleed Screw with Removable Metering Pin** – Allows for easy cleaning of the metering pin without disassembling the valve.
- **Manual External Bleed Screw** – Provides for manual operation in system start up.
- **Manual Internal Bleed through Solenoid** – Provides for manual operation without discharging water outside the valve.
- **Captured Plunger** – Allows for the solenoid to be removed without losing the internal plunger.
- **Five Year Limited Warranty.**

Specifications

OPERATING SPECIFICATIONS

- Pressure Rating: 10 – 150 PSI
- Flow Range: .25 – 30 GPM

7101 PROSERIES 150 1" VALVE

Flow Rate - GPM	5	10	15	20	30
PSI Loss	2.9	2.1	1.8	3.0	5.0

Pressure range: 10-150 psi

7101-FC PROSERIES 150 1" VALVE

Flow Rate - GPM	5	10	15	20	30
PSI Loss	6	4.1	4.1	3.1	6.0

Pressure range: 10-150 psi

ELECTRICAL SPECIFICATIONS

- Standard Solenoid: 24 VAC 60 Hz
- Inrush Current: .43 Amps
- Holding Current: .25 Amps

DIMENSIONS

- Height: 5-1/4" Width: 3-1/8" Length: 5"
- FC Models: Height: 5-7/8" Width: 3-1/8" Length: 5"

Models

7101	1" Female Thread, NPT
7101-SL	1" Female Slip
7101-BSP	1" Female Thread, BSP
7101-BSP-FC	1" Female Thread, BSP with Flow Control
7101-NPT-FC	1" Female Thread, NPT with Flow Control
7101-SL-FC	1" Female Slip with Flow Control

PROSERIES 150 VALVE

PRESSURE RATING: 10 – 150 PSI
FLOW RANGE: .25 – 30 GPM

Application: Residential / Light Commercial / Dirty Water

The ProSeries 150 Valve with Jar-Top provides the professional contractor easy servicing access without removing the valve from the system.



Features and Benefits

- **Heavy Duty, Corrosion and UV Resistant PVC Construction** – Increases the life of the valve.
- **Threaded Jar-Top** – Allows for quick removal of the cap for easy servicing after installation.
- **Manual External Bleed Screw** – Provides for manual operation in system start up.
- **Manual Internal Bleed through Solenoid** – Provides for manual operation without discharging water outside the valve.
- **Captured Plunger** – Allows for the solenoid to be removed without losing the internal plunger.
- **Glass-Filled Nylon Screw Cap** – Increased durability.
- **Five Year Limited Warranty.**

Models

- 7101-J 1" Female Thread Jar-Top, NPT
- 7101-J-SL 1" Female Slip Jar-Top
- 7101-J-BSP 1" Female Thread Jar-Top, BSP
- 7101-J-MXB 1" Male Thread x 1" Barb Jar-Top

No Tools Required

The K-Rain Jar-Top valve allows for quick and easy servicing after installation.



Specifications

OPERATING SPECIFICATIONS

- Pressure Rating: 10 - 150 PSI
- Flow Range: .25 - 30 GPM

PROSERIES 150 1" VALVE WITH JAR-TOP

Flow Rate - GPM	5	10	15	20	30
PSI Loss	3.3	3.9	2.9	3.2	6.1

Pressure range: 10-150 psi

ELECTRICAL SPECIFICATIONS

- Standard solenoid: 24 VAC 60 Cycle
- Inrush Current: .43 Amps
- Holding Current: .25 Amps

DIMENSIONS

- Height: 5-1/4"
- Width: 3"
- Length: 4-3/8"

How to Specify

Model Number	Description
7101-J	Jar Top



PROSERIES 150 VALVES

PRESSURE RATING: 20 – 150 PSI
FLOW RANGE: 20 – 120 GPM

Application: Residential / Light Commercial / Dirty Water

The 1.5" and 2" models feature a removable inlet cap to easily modify the configuration from globe to angle style.

They also have a removable metering pin and external bleed screw promoting easy maintenance and manual operation.



Features and Benefits

- **Heavy Duty, Corrosion and UV Resistant PVC Construction** – Increases the life of the valve.
- **External Bleed Screw with Removable Metering Pin** – Allows for easy cleaning of the metering pin without disassembling the valve.
- **Manual External Bleed Screw** – Provides for manual operation in system start up.
- **Manual Internal Bleed through Solenoid** – Provides for manual operation without discharging water outside the valve.
- **Removable Inlet Cap** – Allows for easy conversion from globe to angle-style valve.
- **Flow Control** – Allows for precise flow adjustment.
- **Captured Plunger** – Allows for the solenoid to be removed without losing the internal plunger.
- **Heavy Duty Santoprene® Diaphragm** – Unique design improves durability of diaphragm.
- **Five Year Limited Warranty.**

Models

7115	1-1/2" Female Thread NPT
7115-BSP	1-1/2" Female Thread, BSP
7102	2" Female Thread NPT
7102-BSP	2" Female Thread, BSP

System Flexibility

Removable inlet cap allows for easy conversion from globe to angle-style valve.



Specifications

OPERATING SPECIFICATIONS

- Pressure Rating: 20 – 150 PSI
- Flow Range: 20 – 120 GPM

PROSERIES 150 1-1/2" VALVE

Flow Rate - GPM	20	30	40	50	60	80
PSI Loss - Globe	3.0	2.6	2.3	2.9	4.1	5.5
PSI Loss - Angle	2.7	2.2	1.9	2.2	3.0	4.4

PROSERIES 150 2" VALVE

Flow Rate - GPM	20	30	40	50	60	80	100	120
PSI Loss - Globe	2.2	1.9	1.7	1.5	1.6	2.9	4.8	6.2
PSI Loss - Angle	1.9	1.9	1.7	1.5	1.5	2.1	3.2	4.6

Pressure range: 20-150 psi

ELECTRICAL SPECIFICATIONS

- Standard solenoid: 24 VAC 60 Cycle
- Inrush Current: .43 Amps
- Holding Current: .25 Amps

DIMENSIONS

- Height: (7115) 8" (7102) 8-7/8"
- Width: (7115) 4-1/4" (7102) 4-7/8"
- Length: (7115) 5-1/2" (7102) 6-1/3"

How to Specify

Model Number	Description
7102	-BSP

PROSERIES 200 VALVES

PRESSURE RATING: 6 – 200 PSI
FLOW RANGE: 5 – 150 GPM

Application: Residential / Light Commercial / Dirty Water

The RPS200 is a durable, feature-packed electric valve designed to handle irrigation applications up to 200 PSI. The glass filled nylon construction and reinforced rubber diaphragm ensure reliable performance.

Standard features such as flow control, top flow indicator, large internal openings and a self-cleaning diaphragm make RPS 200 the ideal choice.

The RPS 200 series valve has a working pressure range from 6 PSI minimum to 200 PSI maximum and recommended flow range from 5 to 150 GPM.



Models

- 7201** 1" Female Thread
- 7201-J** 1" Female Thread Jar-Top
- 7215** 1.5" Female Thread
- 7202** 2" Female Thread

Other options add to part number:

- BSP** Female BSP Inlet and Outlet

How to Specify

Model Number	Description
7201-J	Jar Top

Features and Benefits

- **Durable Glass-filled Nylon Construction and Reinforced Rubber Diaphragm** – Ensures long life and reliable performance.
- **Flow Control** – To adjust water flow as needed (except 7201-J).
- **Large Internal Openings and Self-cleaning Diaphragm During Every Cycle** – Reduces maintenance time.
- **Water Flow Indicator** – Ensures proper installation every time.
- **Electric or Manual Operation**
- **Five Year Limited Warranty**

Specifications

OPERATING SPECIFICATIONS

- Pressure Rating: 20 - 150 PSI
- Flow Range: 5 - 120 GPM

7201 - RPS 200 1" VALVE

Flow Rate - GPM	5	10	15	20	25	30
PSI Loss	.4	1.16	2.45	4.65	7.25	9.70

7201-J - RPS 200 1" VALVE WITH JAR-TOP

Flow Rate - GPM	5	10	15	20	25	30
PSI Loss	1.45	1.9	3.0	5.8	8.75	10.7

7215 - RPS 200 1.5" VALVE

Flow Rate - GPM	20	25	30	40	50	60	80	100
PSI Loss	2.73	3.04	2.90	2.90	3.41	4.24	7.61	12.9

7202 - RPS 200 2" VALVE

Flow Rate - GPM	20	25	30	40	50	60	80	100	120	150
PSI Loss	2.9	2.54	2.17	2.17	2.75	3.4	5.5	7.83	11.66	20.0

Pressure range: 6-200 psi

ELECTRICAL SPECIFICATIONS

- Standard solenoid: 24 VAC
- Inrush current: .43 amp
- Holding current: .25 amp

DIMENSIONS

- **7201 - RPS 200 1" Valve**
Height: 5.25" Width: 3.125" Length: 5.125"
- **7201-J - RPS 200 1" Valve with Jar-Top**
Height: 5.75" Width: 3.125" Length: 4.75"
- **7215 - RPS 200 1.5" Valve**
Height: 6.75" Width: 4.25" Length: 6.25"
- **7202 - RPS 200 2" Valve**
Height: 7" Width: 4.25" Length: 7.25"

PRO EX 2.0

MODULAR IRRIGATION CONTROLLER

Application: Residential / Light Commercial

The Pro EX 2.0 Modular Irrigation Controller can be easily expanded from 4 to 16 stations. The largest backlit display on the market, user-friendly programming and responsive touch pad takes Pro EX 2.0 to a whole new level for irrigation controllers.

The new optional remote capability expands irrigation control right in your hand.



Models

3202	Pro EX 2.0 base unit with 4 station expansion module, 115 VAC internal transformer
3202-P	Pro EX 2.0, modular controller, with pigtail, 115 VAC internal transformer
3202-220	Pro EX 2.0, modular controller, 220 VAC internal transformer
3203	Pro EX 2.0 handheld remote w/batteries
3205	ProEX 2.0, 4 station expansion module
3206	RF module w/short distance antenna
3207	Extended range antenna kit

How to Specify

Model Number	Description
3202	-P

STATION RUN TIMES: 1 sec. – 6 hrs.

NUMBER OF PROGRAMS: 3

AUTOMATIC START TIMES: 4 per program

Features and Benefits

- **Hot-swappable 4 Station Modules** – Allows simple controller upgrades from 4 to 16 stations while controller is in operation.
- **Large Backlit LCD Screen** – Permits maximum viewing for all installations.
- **AM/PM or 24 Hour Clock Settings** – Allows user to choose the time format that is most desirable.
- **Program Display** – Full program screen display of watering days, number of start times, number of stations and special programming.
- **Flexible Operation** – Manual or remote operation.
- **System Test** – Allows a full system check for valve operation.
- **Manual Start** – Allows manual program operation at the push of a button.
- **Wire Management System** – Is made easy with vertical station terminal strips allowing full use of the cabinet.
- **Permanent Memory** – Non-volatile memory saves program during power outages.
- **Remote Programming** – 4 AAA batteries allow for remote programming and LCD viewing.
- **Wireless Module Connector** – Allows for optional installation of wireless communication.
- **Diagnostic Circuit Breaker** – Identifies and isolates stations with valve or wiring problems while allowing remaining program to continue.
- **Advanced Diagnostic** – Visual and/or audible alerts when programming errors or other conditions have been detected and are preventing operation.
- **Locate Feature** – Aids in locating buried valves in field.
- **Station Delay/Overlap** – Permits additional time between stations or dual operation for everyday hydraulic issues like well recovery, slow closing valves and water hammer.
- **Rain Sensor Ready** – Allows programming of individual station(s) operation to be controlled by sensor.
- **Sensor Bypass Switch** – Global override of active sensor for all stations.
- **Master Valve/Pump Start Ready** – Permits programming for individual station(s) operation as needed.
- **Valve Test Terminal (VT)** – Quick and easy matching of field wires with station during installation.
- **Dedicated Sensor Terminals** – Enables direct sensor installation for maximum watering control.
- **Default Programming** – Allows program to be saved and recalled without having to reprogram the controller.
- **Permanent Day Off** – Set any day of the week, regardless of programming, as a non-watering day.
- **Seasonal Adjust** – Conserves water by allowing quick and easy global adjustment of watering times from 10-200%.



Now available with Remote Control, short or long range, for ease of use and increased productivity on every job.

Specifications

OPERATING SPECIFICATIONS

- Station Run Times: 1 second to 6 hours for all stations
- Number of Programs: 3
- Number of Automatic Start Times: 4 per program
- Program Watering Schedules:
Custom (day of the week), Interval (1-31 days),
Odd (odd calendar days), Even (even calendar days)

ELECTRICAL SPECIFICATIONS

- Power Input: 115VAC \pm 10% 60Hz,
230VAC \pm 10% 50Hz
- Power Output: 24VAC 1.25Amp
- Power Backup: Lithium coin-cell battery maintains time and date during primary power outages while the 4 AAA batteries allow for remote programming and LCD viewing.
- Multi-Valve Operation:
Up to three 24VAC, 7VA solenoid valves

DIMENSIONS

- Height: 7-3/4"
- Width: 10"
- Depth: 5"

Optional Remote Feature

The new remote capability expands irrigation control right in your hand:

- Short range: 500' (line of sight)
- Long range: 1000' (line of sight)
- Zone and run time indication
- Zone run time count down
- Visual confirmation of remote controller connection
- Establish your run time per zone up to 99 minutes

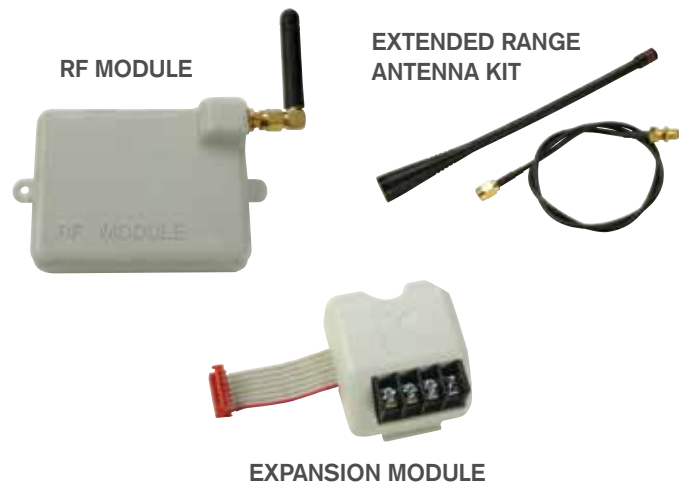

RF MODULE

EXTENDED RANGE ANTENNA KIT

EXPANSION MODULE

RPS® 624

OUTDOOR IRRIGATION CONTROLLER

Application: Residential / Light Commercial

STATION RUN TIMES: 1 min. – 12 hrs. 59 min.

NUMBER OF PROGRAMS: 6

AUTOMATIC START TIMES: 4 per program

A truly versatile controller featuring the latest in micro-processor technology and exclusive low energy, high-output toroidal transformer.

Advanced features include current sensing and station skip with fault indication, and a real time clock maintains time through power outages.



Features and Benefits

- **12, 18 & 24 Station Models Available**
- **6 Fully Independent Programs** – Up to 4 separate start times per program. Max. 24 starts per day.
- **Permanent Memory** – Saves programs during power outages.
- **7 Day Watering Cycle** – Individual day selection, odd/even date selection or interval watering.
- **Rain Off** – Suspends watering during winter while retaining the time and programmed information
- **Flexible Manual Operation** – Choose from automatic, semi-automatic and single station manual.
- **System Test Feature**
- **Water Conservative** – Quick adjustment of watering durations in 10% increments, OFF to 200%.
- **Master Valve/Pump Start**
- **Second Programmable Pump** – Available for dual water supply, fertigation or filtration control.
- **Large Blue and White Backlit LCD** – Easy to read, with "No AC" indicator on LCD when power is out.
- **Current sensing** – On individual stations and faulty station skip feature.
- **Low Energy Micro-processor** – Ensures long battery life.
- **Permanent Real-time Clock** – Maintained by 3V battery-Toroidal high capacity transformer.
- **Outdoor Case** – Lockable and waterproof.
- **Audio Feedback** – On key press and alarm.

Specifications

OPERATING SPECIFICATIONS

- Station Run Times: 1 min. to 12 hours 59 min.
- Number of Programs: 6
- Number of Automatic Start Times: 4 per program

ELECTRICAL SPECIFICATIONS

- Electrical Power Supply:
120 VAC/240 VAC delivering a 24 VAC through a 30VA (1.25A) rated Toroidal transformer
- Electrical Outputs:
24 VAC, 75 AMP
24 VAC, .25 AMP

DIMENSIONS

- Height: 9"
- Width: 9-1/4"
- Depth: 3-1/2"

Models

3912	12 station 110 Volt internal transformer
3912-220	12 station 220 Volt internal transformer
3918	18 station 110 Volt internal transformer
3918-220	18 station 220 Volt internal transformer
3924	24 station 110 Volt internal transformer
3924-220	24 station 220 Volt internal transformer

How to Specify

Model Number	Description
3918	-220

RPS® 469

IRRIGATION CONTROLLER

Application: Residential / Light Commercial

The RPS® 469 has six individual programs to allow for efficient watering on separate programs. This product features Rain Sensor Ready (RSR) technology which allows individual stations to be controlled by a rain sensor.



Features and Benefits

- 4, 6 & 9 Station Models Available
- Indoor/Outdoor
- Weatherproof Enclosure – Ensures long product life.
- System Test – Allows a full system check for valve operation.
- Permanent Memory – Saves programs during power outages.
- 6 Fully Independent Programs – Up to 6 separate start times per program. Max. 36 starts per day.
- Water Conservative – Quick adjustment of watering durations in 10% increments, 10% to 200%.
- Rain Sensor Ready – Allows individual stations to be set and controlled by the sensor.
- Flexible Manual Operation – Choose from automatic, semi-automatic and single station manual.

Models

3604	4 Station, 110 Volt Internal Transformer
3604-220	4 Station, 220 Volt Internal Transformer
3606	6 Station, 110 Volt Internal Transformer
3606-220	6 Station, 220 Volt Internal Transformer
3609	9 Station, 110 Volt Internal Transformer
3609-220	9 Station, 220 Volt Internal Transformer

STATION RUN TIMES: 1 min. – 12 hrs. 59 min.

NUMBER OF PROGRAMS: 6

AUTOMATIC START TIMES: 6 per program

Specifications

OPERATING SPECIFICATIONS

- Station Run Times: 1 min. to 12 hours 59 min.
- Number of Programs: 6
- Number of Automatic Start Times: 6 per program
- Program Watering Schedules: 7 day calendar with individual day selection, or 1 to 15 day interval watering, or 365 day calendar for ODD/EVEN day watering.
- Rain Sensor Ready: Inhibits automatic watering when wet conditions are detected by a suitable rain sensor.
- Master Valve/pump can be enabled or disabled by station or by program.
- Automatic, semi-automatic and single station manual operation.
- Permanent memory saves programs during power outages.

ELECTRICAL SPECIFICATIONS

- Power Input: 120 VAC/240 VAC
- Power Output: 24 Volt AC, 1.0 AMP
- To Solenoid Valve: 24 VAC, 0.75 AMPS max. Note: up to 3 valves per station on inbuilt model.
- Total output load must not be exceeded by the valves and pump start requirements.
- Overload protection: Standard 20mm 1.0 AMP fuse
- Power Failure: 9 Volt standard alkaline battery allows remote programming and display viewing.
- Power Failure: The controller has permanent memory so the data is always backed up even during power outages.
- Wiring: The output circuits should be installed and protected in accordance with wiring rules.

DIMENSIONS

- Height: 8-4/5"
- Width: 7-9/10"
- Depth: 2-9/10"

How to Specify

Model Number	Description
3604	-220

RPS® 46

IRRIGATION CONTROLLER

Application: Residential / Light Commercial

STATION RUN TIMES: 1 min. – 12 hrs. 59 min.

NUMBER OF PROGRAMS: 4

AUTOMATIC START TIMES: 4 per program

RPS® 46 Mini Irrigation Controller, designed for residential applications, has four individual programs to allow for efficient watering on separate programs.

A key feature of this unit is the water budgeting feature which allows easy adjustment of watering schedules as the seasons change.



Features and Benefits

- **4 & 6 Station Models** – Perfect for residential lawns.
- **4 Fully Independent Programs** – Allowing up to 4 starts per program. Maximum 16 starts per day.
- **Indoor Models with External Transformer and Plug.**
- **Seasonal Adjustment** – Allows for quick adjustment of watering durations in 25% increments, from 25% to 150%.
- **Rain Sensor Ready** – Accepts rain sensor and is controlled by bypass switch.
- **Flexible Manual Operation** – Run a program, run a station or test system.
- **Battery Back-Up** – Saves program during power outages.
- **Two Year Limited Warranty.**

Models

3504	4 Station, 110 Volt Internal Transformer
3504-220	4 Station, 220 Volt Internal Transformer
3506	6 Station, 110 Volt Internal Transformer
3506-220	6 Station, 220 Volt Internal Transformer

Specifications

OPERATING SPECIFICATIONS

- Station Run Times: 1 min. to 12 hours 59 min.
- Number of Programs: 4
- Number of Automatic Start Times: 4 per program
- Program Watering Schedules: 7 day calendar with individual day selection, or 1 to 15 day interval watering, or 365 day calendar for ODD/EVEN day watering.
- Rain Sensor Ready: Inhibits automatic watering when wet conditions are detected by a suitable rain sensor.
- Master Valve/pump start terminal.
- Automatic, semi-automatic and single station manual operation.

ELECTRICAL SPECIFICATIONS

- Power Input: 120 VAC/240 VAC
- Power Output: 24 Volt AC, 0.85 AMP
- To Solenoid Valve: 24 VAC, 0.5 AMPS max.
- Total output load must not be exceeded by the valves and pump start requirements.
- Overload protection: Standard 20mm 1.0 AMP fuse
- Power Failure: 9 Volt standard alkaline battery maintains clock and program up to 2 weeks.
- Wiring: The output circuits should be installed and protected in accordance with wiring rules.

DIMENSIONS

- Height: 5-3/4"
- Width: 4-1/2"
- Depth: 1-3/4"

How to Specify

Model Number	Description
3506	-220

BL-KR

BATTERY POWERED CONTROLLER

Application: Residential

No more crawling around the valve box trying to program or troubleshoot a battery powered timer –

The BL-KR timer puts full programming control in the palm of your hand.

With 100% waterproof and rugged construction, the BL-KR is ideal for isolated sites and power-restricted areas. Programming is easy with a few taps on a smartphone or tablet through direct Bluetooth communication up to 32 feet away from the valve box. Add multiple controllers (up to 200 timers) and program simply and quickly from 1 free application.

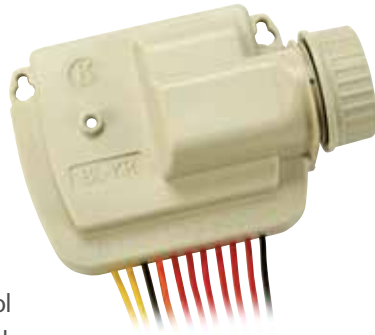

Specifications

OPERATING SPECIFICATIONS

- 1,2,4,6 stations
- Master valve connection (Except for BL-KR1 single station)
- Rain/freeze sensor connection
- Bluetooth range; 32 ft (10m)

ELECTRICAL SPECIFICATIONS

- Works with 9V latching solenoids and a master valve equipped with a 9V latching solenoid
- Maximum distance between the timer and solenoid is 98 ft (30m) with 15 AWG (.05" or 1,55mm²)

DIMENSIONS

- Height: 2.16 inches (5.5 cm)
- Width: 5.5 inches (14 cm)
- Depth: 3.54 inches (9 cm)

Models

BL-KR1	1 Station
BL-KR2	2 Station
BL-KR4	4 Station
BL-KR6	6 Station



STATIONS: Available in 1, 2, 4 and 6 stations

NUMBER OF PROGRAMS: 8

BLUETOOTH RANGE: 32 ft. (10m)

Features and Benefits

BL-KR BATTERY POWERED CONTROLLER TIMER

- Easy programming from most smartphones or tablets; full program display makes programming easy to understand
- Communicates directly with most smartphones/tablets
- Indoor or outdoor installation
- IP68 certified 100% waterproof and fully submersible—Ruggedly designed for installation in the valve box
- Molded out of UV resistant, high impact ABS resin
- Eliminates need to purchase expensive remotes
- Waterproof and independent battery housing
- Ideal for isolated/remote valve boxes where running power is expensive/difficult
- Ideal for multi-housing developments with shared point of source or for splitting/adding zones when all stations have been used on a conventional controller
- Eliminates long wire runs to controller or expensive increase in wire gauge size due to voltage drop issues
- Bluetooth low energy communication
- Standalone – works with a 9V alkaline battery type
- Non-volatile memory will save programming in case of battery failure
- Available in 1, 2, 4 and 6 station models
- Rain/freeze sensor ready



FREE SMARTPHONE/TABLET APPLICATION

- Transforms your iOS or Android smartphone or tablet into a remote control and fully program your BL-KR controller(s) using Bluetooth Smart technology from up to 32 feet away
- Manually start, stop, or suspend your controller(s) from up to 32 feet away
- Fully configure watering schedules and zones
- Detect battery levels/connection status
- Add a passcode lock to each controller for added security
- Add multiple BL-KR controllers (up to 200) and program/control them using 1 app on your smartphone or tablet

How to Specify

Model Number	Description
BL-KR2	2 Station

SINGLE STATION CONTROLLER

Application: Industrial

K-Rain's 2000 Series Single Station Controllers look great and stay safe with rain-tight, attractive enclosures.



Features and Benefits

- **Industrial, Rain Tight, Secure, Rustproof Enclosure** – Industrial-grade enclosure ensures long product life and deters tampering.
- **U.L. Approved components.**
- **Large Easy Access Enclosure** – Provides easy accessibility during wiring.
- **Enclosure has 8 Recessed Knock-Outs** – Provides easy connections from any direction.
- **110 VAC or 24 VAC Coils Available** – Provides for a variety of applications up to 10 HP.
- **Plastic Inset Cover Screws** – Extra system security, reduces liability and deters tampering.
- **Two Year Limited Warranty.**

How to Specify

Model Number	Description
2110	Single Pole, Single Throw

Models

2100 SINGLE STATION CONTROLLERS

Model	Voltage	Rating
2110	Input: 110 VAC, 60 Hz Output: 110 VAC, 60 Hz	Single Pole, Single Throw Relay Rated for up to 1 H.P.
2112	Input: 110 VAC, 60 Hz Output: 110 VAC, 60 Hz	Double Pole, Single Throw Relay Rated for up to 2 H.P.
2114	Input: 110 VAC, 60 Hz Output: 24 VAC, 30 VA	Built-In Transformer
2116	Input: 110 VAC, 60 Hz Output: n/a	Hydraulic 1/2 Gallon Pole, Single Throw
2120	Input: 220 VAC, 60 Hz Output: 220 VAC, 60 Hz	Double Pole, Single Throw Relay Rated for up to 2 H.P.
2124	Input: 220 VAC, 60 Hz Output: 24 VAC, 20 VA	Built-In Transformer

2500 RAINSWITCH-READY CONTROLLERS

Model	Voltage	Rating
2510	Input: 110 VAC, 60 Hz Output: 110 VAC, 60 Hz	Double Pole, Single Throw Relay Rated for up to 2 H.P.
2514	Input: 110 VAC, 60 Hz Output: 24 VAC, 30 VA	Built-In Transformer
2520	Input: 220 VAC, 60 Hz Output: 220 VAC, 60 Hz	Double Pole, Single Throw Relay Rated for up to 2 H.P.

2200 SHORT DURATION SINGLE STATION CONTROLLERS

Model	Voltage	Rating
2210	Input: 110 VAC, 60 Hz Output: 110 VAC, 60 Hz	Relay Rated for up to 1 H.P.
2214	Input: 110 VAC, 60 Hz Output: 24 VAC, 30 VA	Built-In Transformer



PUMP START RELAY

Application: Industrial

The Pump Start Relay enclosure is constructed with a corrosion resistant, UV resistant and shockproof material. The rain-tight, secure, rustproof enclosure provides a safe and secure connection in a housing built to last.

Pump Start Relays are U.L. rated and available to operate 2 HP up to 10 HP pumps; coils are available in 110 VAC and 24 VAC.



Features and Benefits

- **Industrial, Rain Tight, Secure, Rustproof Enclosure** – Industrial-grade enclosure ensures long product life and deters tampering.
- **U.L. Approved Components.**
- **Large Easy Access Enclosure** – Provides easy accessibility during wiring.
- **Enclosure has 8 Recessed Knock-Outs** – Provides easy connections from any direction.
- **110 VAC or 24 VAC Coils Available** – Provides for a variety of applications up to 10 HP.
- **Plastic Inset Cover Screws** – Extra system security, reduces liability and deters tampering.
- **Two Year Limited Warranty.**

Specifications

DIMENSIONS

- Height: 7"
- Width: 5"
- Length: 4-5/8"

Models

<p>1510 Coil Specifications 120 VAC, 60 Hz Inrush: 35 VA Sealed: 7.0 VA Resistance (±10%): 250 OHMS</p> <p>Mini Coil 24 VAC, 50/60 Hz Inrush: 52 mA</p>	<p>Double Pole, Single Throw Inductive: 20 AMP Resistive: 30 AMP Input: 120 VAC - up to 2 H.P. UL Rated</p> <p>Sealed: 1.2 VA Resistance (±10%): 155 OHMS</p>
<p>1520 Coil Specifications 240 VAC, 60 Hz Inrush: 35 VA Sealed: 7.0 VA Resistance (±10%): 1000 OHMS</p> <p>Mini Coil 24 VAC, 50/60 Hz Inrush: 52 mA</p>	<p>Double Pole, Single Throw Inductive: 20 AMP Resistive: 30 AMP Input: 240 VAC - up to 3 H.P. UL Rated</p> <p>Sealed: 1.2 VA Resistance (±10%): 155 OHMS</p>
<p>1522 Coil Specifications 24 VAC, 60 Hz Inrush: 35 VA Sealed: 7 VA, 3 Watts Resistance (±10%): 11 OHMS</p>	<p>Double Pole, Single Throw Inductive: 20 AMP Resistive: 30 AMP Input: 120 VAC - up to 3 H.P. 240 VAC - up to 3 H.P.</p>
<p>1521 Coil Specifications 110 VAC, 60 Hz Inrush: 42 VA Sealed: 8.5 VA, 3.6 Watts Resistance (±10%): 210 OHMS</p>	<p>Double Pole, Single Throw Inductive: 20 AMP Resistive: 30 AMP Input: 120 VAC - up to 3 H.P. 240 VAC - up to 3 H.P.</p>
<p>1552 Coil Specifications 24 VAC, 60 Hz Inrush: 60 VA Sealed: 7 VA, 2.3 Watts Resistance (±10%): 5.61 OHMS</p>	<p>Double Pole, Single Throw Inductive: 40 AMP Resistive: 50 AMP Input: 120 VAC - up to 3 H.P. 240 VAC - up to 5 H.P.</p>
<p>1551 Coil Specifications 110 VAC, 60 Hz Inrush: 77 VA Sealed: 10 VA, 4 Watts Resistance (±10%): 89.5 OHMS</p>	<p>Double Pole, Single Throw Inductive: 40 AMP Resistive: 50 AMP Input: 120 VAC - up to 3 H.P. 240 VAC - up to 5 H.P.</p>
<p>1553 Coil Specifications 24 VAC, 60 Hz Inrush: 60 VA Sealed: 7 VA, 2.7 Watts Resistance (±10%): 5.61 OHMS</p>	<p>THREE PHASE OPERATION Triple Pole, Single Throw Inductive: 40 AMP Resistive: 50 AMP Input: 120 VAC - up to 3 H.P. 240 VAC - up to 10 H.P.</p>

How to Specify

Model Number	Description
1552	Pump Start Relay

4000 SERIES INDEXING VALVE

Application: Residential / Light Commercial

The 4000 offers a reliable, economical way to automate multiple zoned residential and small commercial irrigation systems.

These patented indexing valves allow for the number of watering zones to be changed quickly and easily.

They are ideally suited for both city water and pump applications and may also be used for onsite wastewater or effluent water applications. The simplicity of design and few moving parts ensures ease of maintenance and long service life.

The 4000 valve is available in 4 or 6 outlet models. A quick change of the cam allows the valve to operate from 2 to 6 zones.

The valve will operate with flows as low as 10 GPM and at pressures of 25 to 75 PSI.



Features and Benefits

- **ABS Polymer Construction** – High-strength, non-corrosive body for long product life.
- **Available in 4 and 6 Outlet Models** – Can quickly and easily change from two to six watering zones.
- **Simplicity of Design** – Valves are easily maintained and serviced for long product life.
- **Operates at Low 10 GPM at Pressures of 25-75 PSI** – Reliably automates multiple zoned residential and small commercial irrigation or wastewater systems.
- **Two Year Limited Warranty.**

Specifications

- Constructed of High Strength, Non-Corrosive ABS Polymer
- 4000 Series Valves are available with 1" inlet and outlet by custom order

OPERATING SPECIFICATIONS

- Pressure Rating: 25 – 75 PSI
- Flow Range:
 - 4 Outlet Valve: 10-40 GPM
 - 6 Outlet Valve: 10-40 GPM
- Pressure Loss:

4 OUTLET VALVE

Flow Rate - GPM	10	20	30	40
PSI Loss	2.0	3.0	4.5	6.4

6 OUTLET VALVE

Flow Rate - GPM	10	20	30
PSI Loss	2.5	4.5	7.5

DIMENSIONS

- Height: 5-3/4"
- Width: 5-3/4"

How to Specify

Model Number	Description
4402	4 Outlets, 2 Zones

Models

FOUR OUTLET, 1 1/4" X 1-1/4" MODELS

4400	No Cam
4402	Cammed for 2 Zone Operation
4403	Cammed for 3 Zone Operation
4404	Cammed for 4 Zone Operation

SIX OUTLET, 1 1/4" X 1" MODELS

4600	No Cam
4602	Cammed for 2 Zone Operation
4603	Cammed for 3 Zone Operation
4604	Cammed for 4 Zone Operation
4605	Cammed for 5 Zone Operation
4606	Cammed for 6 Zone Operation

Other options add to part number:

-RCW Reclaimed Water Use

6000 SERIES INDEXING VALVE

Application: Industrial

The 6000 line of indexing valves offers exceptional reliability and durability even under the dirtiest water conditions.

With a metal die-cast body, the 6000 valves are capable of high pressure applications and are recommended to be used on pump fed systems or high-flow city water systems. The 6000 is also ideal for onsite wastewater and effluent water applications.



The 6000 valve is available in 4 or 6 outlet models that are cammed for 2 to 6 zone operation. With only one moving part (the stem and disc assembly), the valve is easily serviced and maintained.

The valve requires 15 GPM to operate and works at pressures from 25 to 150 PSI.

Features and Benefits

- **Metal Die-Cast Body** – Durable, long lasting and capable of high pressure applications.
- **Available in 4 and 6 Outlet Models** – Can quickly and easily change from two to six watering zones.
- **Simplicity of Design** – Valves are easily maintained and serviced for long product life.
- **Operates at 15 GPM at Pressures of 25–150 PSI** – Ideal for pump-fed systems or high-flow city water systems.
- **Built-in Atmospheric Vacuum Breaker** – Releases any vacuum created between the pump and the valve on shut down.
- **Two Year Limited Warranty.**

Specifications

- **Construction:**
Valve Top/Housing: Die Cast Metal
Valve Outlets: High Strength ABS Polymer
- **Inlet:** Threaded 1-1/2" NPT Connection
- **Outlets:** Slip and Glue Connections to 1-1/2" PVC Pipe

OPERATING SPECIFICATIONS

- **Pressure Rating:** 25 - 150 PSI
- **Flow Range:** 15-150 GPM
- **Pressure Loss:**

4 OUTLET VALVE

Flow Rate - GPM	20	40	60	80	100
PSI Loss	2.5	3.5	5.0	7.5	10.0

6 OUTLET VALVE

Flow Rate - GPM	20	40	60	80	100
PSI Loss	3.0	4.0	6.0	9.0	11.0

Models

FOUR OUTLET MODELS

6402	Cammed for 2 Zone Operation
6403	Cammed for 3 Zone Operation
6404	Cammed for 4 Zone Operation

SIX OUTLET MODELS

6605	Cammed for 5 Zone Operation
6606	Cammed for 6 Zone Operation

Other options add to part number:

-RCW Reclaimed Water Use

DIMENSIONS

- Height: 7"
- Width: 8"

How to Specify

Model Number	Description
6402	4 Outlets, 2 Zones





RECLAIMED WATER (RCW)

Application: Reclaimed/Non-Potable Water

K-Rain is the leading manufacturer of Rotors, Sprays and Distribution Valves for the reclaimed water industry. The process of reclaiming water, also called “water recycling”, involves a highly engineered, multi-step treatment process that speeds up nature’s restoration of water. Reclaimed water can come from the following sources:

- 1] **Reclaimed wastewater** – gray water processed off-site and provided through the local municipality for irrigation purposes.
- 2] **On-site wastewater** – derived from domestic wastewater or ‘gray water’ and processed through an on-site wastewater treatment system for irrigation purposes.
- 3] **Storm water** – derived directly from ponds, canals, etc. for irrigation purposes.

Benefits of using reclaimed water for irrigation include:

- Costs less than drinking water and reduces stress on drinking water supplies.
- Reduces sewer treatment costs through reduced household water usage.
- Reduces fertilizer use, as some nutrients like nitrogen and phosphorus remain after the recycling process.
- Reduces gray water disposal into waterways, which can help reduce nutrient loads in bays and rivers. These nutrients facilitate algae overgrowth, robbing the water of oxygen and killing indigenous fish and other marine wildlife.



4000 SERIES
INDEXING VALVES



6000 SERIES
INDEXING VALVE



PRO-S™

K-SPRAY™

RCW SERIES

Rotors, Sprays and Indexing Valves for Reclaimed Water

Worldwide regulations frequently require reclaimed water usage sites to use components identified with a purple cap or collar. K-Rain manufactures an entire line of rotors, sprays and indexing valves to help you adhere to these rules.

The RCW series is designed specifically for use on reclaimed water systems. Flexibility in system design, achieved through a wide selection of nozzles, guarantees matched precipitation.

RCW models are available in K-Spray™, Pro-S™ Spray, MiniPro™, ProPlus™, RPS® 75, SuperPro™, ProSport™ and indexing valve products.



Features and Benefits

RCW ROTORS

- **Heavy Duty Rubber Cover (purple)** – Seals out dirt and increases product durability, positively identifies the use of reclaimed water reducing liability.

RCW SPRAYS

- **Accepts Low Angle Nozzle** – Ensures the correct trajectory of reclaimed water.

RCW INDEXING VALVES

- **Available in 4 and 6 Outlet Models** – Watering zones can be changed quickly and easily.
- **4000 RCW Indexing Valve** – Automates multiple zoned residential and small commercial wastewater systems
- **6000 RCW Indexing Valve** – Metal die-cast body is capable of high pressure applications

Models

Please refer to product pages for individual product model numbers.

PRODUCT	PAGE
MiniPro™	02
RPS® 75	06
ProPlus™	12
SuperPro™	14
ProSport™	16
Pro-S™	18
K-Spray™	21
4000 Series Valves	44
6000 Series Valves	45

How to Specify

Model Number	Description
73001	-RCW

ACCESSORIES

Nozzle Racks

Item Number	Item Description
P52775	MiniPro Nozzle Rack (red) .75, 1, 2, 3 GPM nozzles included (2.5 GPM nozzle preinstalled)
P51399	ProPlus, SuperPro Nozzle Rack (red) 0.5, 0.75, 1, 2, 3, 4, 6, 8 GPM standard nozzles and 1, 3, 4, 6 GPM low angle nozzles included (2.5 GPM nozzle preinstalled)
P16001101	RPS 75, RPS 75i Nozzle Rack (red) 0.75, 1, 1.5, 2, 4, 6, 8 GPM standard nozzles and 1, 3, 4, 6 GPM low angle nozzles included (3.0 GPM nozzle preinstalled)



MiniPro
Nozzle
Rack

ProPlus,
SuperPro
Nozzle
Rack

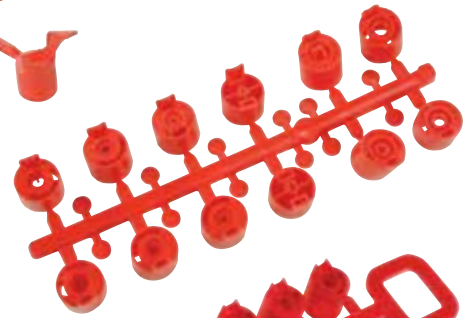

RPS 75,
RPS 75i
Nozzle
Rack

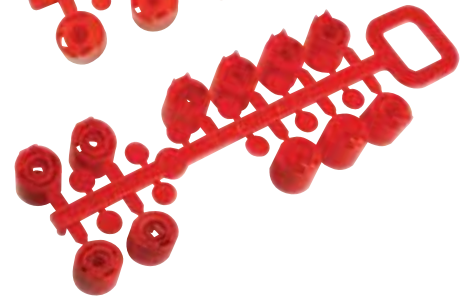

ProSport® Replacement Nozzles

Item Number	Item Description
14055130	5 GPM (white)
Includes one of each nozzle.	10 GPM (green)
	15 GPM (grey)
	20 GPM (brown)
	25 GPM (blue)
	30 GPM (black)



SuperPro, RPS Select
Adjustment Key



Adjustment Tools

Item Number	Item Description
P59995	K-Key; MiniPro, ProPlus Adjustment Key
P1000902	SuperPro, RPS Select Adjustment Key
P1000901	RPS 75, RPS 75i Adjustment Key
RN-ADJ-TOOL	Rotary Nozzle Adjustment Tool



K-Key; MiniPro, ProPlus
Adjustment Key



Rotary Nozzle
Adjustment Tool



RPS 75, RPS 75i
Adjustment Key



Rotor Accessories

Item Number	Item Description	Riser Clip	MiniPro Check Disk	RPS 75, 75i, Select Check Disk Assembly	ProSport Check Disk	ProPlus, SuperPro Check Disk
P54065	Riser Clip					
P513995	MiniPro Check Disk					
P16009116	RPS 75, 75i, Select Check Disk Assembly					
P53425	ProSport Check Disk					
P51210	ProPlus, SuperPro Check Disk					
P51114	MiniPro Filter Basket		MiniPro Filter Basket	RPS 75, 75i, Select Filter Basket	ProPlus, SuperPro Filter Basket	
P51115	RPS 75, 75i, Select Filter Basket					
P51112	ProPlus, SuperPro Filter Basket					

Spray Accessories

Item Number	Item Description	Female Shrub Adapter	Male Shrub Adapter	K-Spray Check Disk	Rotary Nozzle Guard
PSA	Shrub Adapter, Female Thread (for male nozzles)				
PFSA	Shrub Adapter, Male Thread (for female nozzles)				
P53426	K-Spray Check Disk				
P53428	Pro-S Check Disk	Pro-S Check Disks	NP Spray Check Disk		
P53429	NP Spray Check Disk				
78000	Rotary Nozzle Guard (fits Pro-S Sprays)				

Valve Accessories

P3008114	9V DC Latching Solenoid		9V DC Latching Solenoid		24V AC Solenoid
P3008113	24V AC Solenoid				

Pro Ex 2.0 Accessories

3203	Pro EX 2.0 handheld remote w/batteries		Handheld Remote Control		Extended Range Antenna Kit
3205	ProEX 2.0, 4 station expansion module		4 Station Expansion Module		RF Module with Short Distance Antenna
3206	RF module w/short distance antenna				
3207	Extended range antenna kit				



The right products for every landscape.

CHARTS

Conversion Table for U.S. and Metric Systems

METRIC TO U.S.				
MULTIPLY		TO OBTAIN		
Millimeters (mm)	x	.03937	=	inches
Centimeters (cm)	x	.3937	=	inches
Meters (m)	x	39.37	=	inches
Meters (m)	x	3.281	=	feet
Meters (m)	x	1.094	=	yards
Kilometers (km)	x	.62137	=	miles
Kilometers (km)	x	1093.62	=	yards
Kilometers (km)	x	3280.87	=	feet
Liters (l)	x	1.0567	=	quarts (liq.)
Liters (l)	x	.2642	=	gallons (U.S.)
Liters (l)	x	.455	=	pounds
Temp. in (C° x 1.80)	+	32°	=	temp. in F°

U.S. TO METRIC				
MULTIPLY		TO OBTAIN		
Inches (in.)	x	25.4	=	millimeters
Inches (in.)	x	2.54	=	centimeters
Inches (in.)	x	.0254	=	meters
Feet (ft.)	x	.3048	=	meters
Yards (yds.)	x	.9144	=	meters
Miles (mi.)	x	1.6093	=	kilometers
Yards (yds.)	x	.0009143	=	kilometers
Feet (ft.)	x	.0003048	=	kilometers
Quarts (qts.)	x	.945	=	liters
Gallons	x	3.78	=	liters
Pounds	x	2.2	=	liters
Temp. in F° - 32°	x	.5666	=	temp. in C°

Kilograms per cubic centimeter (kg/cm²)	x	14.223	=	Pounds per square inch (P.S.I.)
Cubic Foot (cu. ft.) x 28.316			=	Liters (l.)

MISCELLANEOUS CONVERSION FACTORS					
Feet head (ft. hd.) x .433	=	Pounds per square inch (P.S.I.)	Calorie x 3.968	=	British Thermal Unit (B.T.U.)
Pounds per square inch x 2.31	=	Feet head	Foot pounds per second x .7373	=	Watts
Meters x 3.28	=	Feet head	Kilowatts x 1.34	=	Horsepower
Inches of mercury x 1.133	=	Feet head	Square foot x 144	=	Square inches
U.S. gallons per minute x .1337	=	Cubic feet per minute	Square yard x 9	=	Square feet
Cubic feet per minute x 7.48	=	U.S. gallons per minute	Acre x 4.840	=	Square yards
British Imperial gallon x 1.201	=	U.S. gallons	Acre x 43,560	=	Square feet
Acre inches per hour x 453	=	G.P.M.	Square mile (section) x 640	=	Acres
Acre foot per day x 226	=	G.P.M.	Mile x 5280	=	Feet
1,000,000 gallons per day	=	694 G.P.M.	Cubic yard x 27	=	Cubic Feet
U.S. gallons x .833	=	British Imperial gallon	Circumference of circe x .3183	=	Diameter of circle
U.S. gallon x 8.336	=	Pounds	Diameter of circe x 3.1416	=	Circumference of circle
Acre foot x 325,850	=	U.S. gallons	Diameter of circle squared x .7854	=	Area of circle
Gallons per day x 1,000,000	=	694 gallons per minute	Radius of circle squared x 3.1416	=	Area of circle
U.S. gallons x 231	=	Cubic inches	Cubic Feet per second x 448.8	=	U.S. gallons per minute
Horsepower (H.P.) x 746	=	Watts	Cubic feet per second	=	Gallons per minute - 449
Horsepower x .746	=	Kilowatts	Velocity in feet per second	=	$\frac{.408 \times \text{U.S. g.p.m.}}{\text{Diam. of pipe squared}}$
					or
					$\frac{144Q \text{ (flow in G.P.M.)}}{A1 \text{ (Pipe ID2)}}$

CHARTS

Resistance and Valve Wire Sizing

Resistance Method

Required Information

- Actual one-way length of wire between the controllers and at the power source of the controllers and valves
- Allowable voltage loss along the wire circuit
- Accumulative current flowing through the wire section being sized in amperes

Resistance is calculated using formula:

$$R = \frac{1000 \times AVL}{2L \times I}$$

R = Maximum Allowable Resistance of wire in ohms per 1000 feet

AVL = Allowable voltage loss

L = Wire length (one way)

I = Inrush current

AVL for controller power wire sizing is calculated by subtracting minimum operating voltage required by the controller from minimum available voltage at power source.

AVL for valve wire sizing is calculated by subtracting minimum solenoid operating voltage from controller output voltage. This number will vary depending on the manufacturer and in some cases with line pressure.

Valve Wire Sizing Example:

Given: The distance from the controller to the valve is 1800 ft. The controller output is 24V. The valve has a minimum operating voltage of 20V and an inrush current of 370 mA (0.37Amps).

$$R = \frac{1000 \times 4}{2(1800) \times 0.37}$$

$$R = \frac{4000}{332}$$

$$R = 3.00 \text{ ohms/1000 feet}$$

Wire resistance can not exceed 3.00 ohms per 1000 feet. Go to table #1 and select the proper wire size. Since 16 gauge wire has more resistance than 3.00 ohms per 1000 feet, choose 14 gauge wire.

Table 2 is a quick reference and is set up to provide maximum wire runs given the information at the bottom of the table.

WIRE SIZE AWG No.	Resistance at 20° C (68° F) ohms per 1000 Feet
18	6.39
16	4.02
14	2.52
12	1.59
10	1.00
8	0.63
6	0.40
4	0.25

GROUND WIRE	CONTROL WIRE						
	18	16	14	12	10	8	6
18	850	1040	1210	1350	1460	1540	1590
16	1040	1340	1650	1920	2150	2330	2440
14	1210	1650	2150	2630	3080	3450	3700
12	1350	1920	2630	3390	4170	4880	5400
10	1460	2150	3080	4170	5400	6670	7690
8	1540	2330	3450	4880	6670	8700	10530
6	1590	2440	3700	5400	7690	10530	13330

Solenoid: 24VAC, Pressure: 150 PSI, Voltage Drop: 4V, Min. Operating Voltage: 20V, Amperage Peak: .37A

PRECIPITATION RATES	(U.S.)	(METRIC)
Equilateral Triangular Spacing	P.R.= (in/hr) $\frac{(GPM \text{ of } 360) \times 96.25}{(\text{Head Spacing})^2 \times .866}$	P.R.= (mm/hr) $\frac{m3/hr \text{ of } 360 \times 1000}{m^2 \times .866}$
Square/Rectangular Spacing	P.R.= (in/hr) $\frac{(GPM \text{ of } 360) \times 96.25}{\text{head Spacing} \times \text{Row Spacing}}$	P.R.= (mm/hr) $\frac{m3/hr \text{ of } 360 \times 1000}{\text{Degrees of Arc} \times \text{Head Spacing}}$
Square/Rectangular Spacing for Specific Arc	P.R.= (in/hr) $\frac{3460 \times GPM \text{ (for any arc)}}{\text{Degrees of Arc} \times \text{Head Spacing} \times \text{Row Spacing}}$	P.R.= (mm/hr) $\frac{m3/hr \text{ (for any arc)} \times 1000}{\text{Degrees of Arc} \times \text{Head Spacing} \times \text{Row Spacing}}$
Horsepower	H.P. = $\frac{GPM \times Ft \text{ of Head}}{3,960 \times \text{Pump Efficiency (expressed as a decimal)}}$	
Station Run Time	S.R.T.= (min/wk) $\frac{\text{Total Weekly Req'd (inch/wk)} \times 60 \text{ (min/hr)}}{\text{Precipitation Rate (in/hr)}}$	S.R.T.= (min/wk) $\frac{\text{Total Weekly Req'd (mm/wk)} \times 60 \text{ (min/hr)}}{\text{Precipitation Rate (mm/hr)}}$
Pipe Velocity	V= (ft/sec) $\frac{0.4085 \times \text{Flow (GPM)}}{(\text{Inside Pipe Diameter in Inches})^2}$	V= (m/sec) $\frac{1273.24 \times \text{Flow (l/sec)}}{(\text{Inside Pipe Diameter in Millimeters})^2}$
Scheduling Coefficient	S.C.= $\frac{\text{Average Precipitation Rate (in/hr)}}{\text{Lowest Precipitation Rate (in/hr)}}$	S.C.= $\frac{\text{Average Precipitation Rate (mm/hr)}}{\text{Lowest Precipitation Rate (mm/hr)}}$
Slope	S= $\frac{\text{Rise (Measure of Length)}}{\text{Run (Measure of Length)}}$	

CHARTS

PVC Schedule 40 IPS Plastic Pipe

SIZES: 1/2" through 6"

FLOW: 1 – 600 GPM

PSI LOSS: Per 100' of tube (PSI/100 FT)

C = 150 (1120, 1220)

SIZE	1/2"		3/4"		1"		1 1/4"		1 1/2"		2"		2 1/2"		3"		4"		6"	
OD	0.840		1.050		1.315		1.660		1.900		2.375		2.875		3.500		4.500		6.625	
ID	0.622		0.824		1.049		1.380		1.610		2.067		2.469		3.068		4.026		6.065	
WALL THK.	0.109		0.113		0.133		0.140		0.145		0.154		0.203		0.216		0.237		0.280	
FLOW G. P. M.	Velocity FPS	psi Loss	Velocity FPS	psi Loss	Velocity FPS	psi Loss	Velocity FPS	psi Loss	Velocity FPS	psi Loss	Velocity FPS	psi Loss	Velocity FPS	psi Loss	Velocity FPS	psi Loss	Velocity FPS	psi Loss	Velocity FPS	psi Loss
1	1.05	0.43	0.60	0.11	0.37	0.03	0.21	0.01	0.15	0.00										
2	2.11	1.55	1.20	0.39	0.74	0.12	0.42	0.03	0.31	0.02	0.19	0.00								
3	3.16	3.28	1.80	0.84	1.11	0.26	0.64	0.07	0.47	0.03	0.28	0.01	0.20	0.00						
4	4.22	5.60	2.40	1.42	1.48	0.44	0.85	0.12	0.62	0.05	0.38	0.02	0.26	0.01						
5	5.27	8.46	3.00	2.15	1.85	0.66	1.07	0.18	0.78	0.08	0.47	0.02	0.33	0.01	0.21	0.00				
6	6.33	11.86	3.60	3.02	2.22	0.93	1.28	0.25	0.94	0.12	0.57	0.03	0.40	0.01	0.26	0.01				
7	7.38	15.77	4.20	4.01	2.59	1.24	1.49	0.33	1.10	0.15	0.66	0.05	0.46	0.02	0.30	0.01				
8	8.44	20.20	4.80	5.14	2.96	1.59	1.71	0.42	1.25	0.20	0.76	0.06	0.53	0.02	0.34	0.01				
9	9.49	25.12	5.40	6.39	3.33	1.97	1.92	0.52	1.41	0.25	0.85	0.07	0.60	0.03	0.39	0.01				
10	10.55	30.54	6.00	7.77	3.70	2.40	2.14	0.63	1.57	0.30	0.95	0.09	0.66	0.04	0.43	0.01				
11	11.60	36.43	6.60	9.27	4.07	2.86	2.35	0.75	1.73	0.36	1.05	0.11	0.73	0.04	0.47	0.02				
12	12.65	42.80	7.21	10.89	4.44	3.36	2.57	0.89	1.88	0.42	1.14	0.12	0.80	0.05	0.52	0.02	0.30	0.00		
14	14.76	56.94	8.41	14.48	5.19	4.47	2.99	1.18	2.20	0.56	1.33	0.17	0.93	0.07	0.60	0.02	0.35	0.01		
16	16.87	72.92	9.61	18.55	5.93	5.73	3.42	1.51	2.51	0.71	1.52	0.21	1.07	0.09	0.69	0.03	0.40	0.01		
18	18.98	90.69	10.81	23.07	6.67	7.13	3.85	1.88	2.83	0.89	1.71	0.26	1.20	0.11	0.78	0.04	0.45	0.01		
20	21.09	110.23	12.01	28.04	7.41	8.66	4.28	2.28	3.14	1.08	1.90	0.32	1.33	0.13	0.86	0.05	0.50	0.01		
22			13.21	33.45	8.15	10.33	4.71	2.72	3.46	1.29	2.10	0.38	1.47	0.16	0.95	0.06	0.55	0.01		
24			14.42	39.30	8.89	12.14	5.14	3.20	3.77	1.51	2.29	0.45	1.60	0.19	1.04	0.07	0.60	0.02		
26			15.62	45.58	9.64	14.08	5.57	3.17	4.09	1.75	2.48	0.52	1.74	0.22	1.12	0.08	0.65	0.02		
28			16.82	52.28	10.38	16.15	5.99	4.25	4.40	2.01	2.67	0.60	1.87	0.25	1.21	0.09	0.70	0.02		
30			18.02	59.41	11.12	18.35	6.42	4.83	4.72	2.28	2.86	0.68	2.00	0.29	1.30	0.10	0.75	0.03		
35					12.97	24.42	7.49	6.43	5.50	3.04	3.34	0.90	2.34	0.38	1.51	0.13	0.88	0.04	0.38	0.00
40					14.83	31.27	8.56	8.23	6.29	3.89	3.81	1.15	2.67	0.49	1.73	0.17	1.00	0.04	0.44	0.01
45					16.68	38.89	9.64	10.24	7.08	4.84	4.29	1.43	3.01	0.60	1.95	0.21	1.13	0.06	0.49	0.01
50					18.53	47.27	10.71	12.45	7.87	5.88	4.77	1.74	3.34	0.73	2.16	0.26	1.25	0.07	1.55	0.01
55							11.78	14.85	8.65	7.01	5.25	2.08	3.68	0.88	2.38	0.30	1.38	0.08	0.61	0.01
60							12.85	17.45	9.44	8.24	5.72	2.44	4.01	1.03	2.60	0.36	1.51	0.10	0.66	0.01
65							13.92	20.23	10.23	9.56	6.20	2.83	4.35	1.19	2.81	0.41	1.63	0.11	0.72	0.02
70							14.99	23.21	11.01	10.96	6.68	3.25	4.68	1.37	3.03	0.48	1.76	0.13	0.77	0.02
75							16.06	26.37	11.80	12.46	7.16	3.69	5.01	1.56	3.25	0.54	1.88	0.14	0.83	0.02
80							17.13	29.72	12.59	14.04	7.63	4.16	5.35	1.75	3.46	0.61	2.01	0.16	0.88	0.02
85							18.21	33.26	13.37	15.71	8.11	4.66	5.68	1.96	3.68	0.68	2.13	0.18	0.94	0.02
90							19.28	36.97	14.16	17.46	8.59	5.18	6.02	2.18	3.90	0.76	2.26	0.20	0.99	0.03
95									14.95	19.30	9.07	5.72	6.35	2.41	4.11	0.84	2.39	0.22	1.05	0.03
100									15.74	21.22	9.54	6.29	6.69	2.65	4.33	0.92	2.51	0.25	1.10	0.03
110									17.31	25.32	10.50	7.51	7.36	3.16	4.76	1.10	2.76	0.29	1.22	0.04
120									18.88	29.75	11.45	8.82	8.03	3.72	5.20	1.29	3.02	0.34	1.33	0.05
130											12.41	10.23	8.70	4.31	5.63	1.50	3.27	0.40	1.44	0.05
140											13.36	11.74	9.37	4.94	6.06	1.72	3.52	0.46	1.55	0.06
150											14.32	13.33	10.03	5.62	6.50	1.95	3.77	0.52	1.66	0.07
160											15.27	15.03	10.70	6.33	6.93	2.20	4.02	0.59	1.77	0.08
170											16.23	16.81	11.37	7.08	7.36	2.46	4.27	0.66	1.88	0.09
180											17.18	18.69	12.04	7.87	7.80	2.74	4.53	0.73	1.99	0.10
190											18.14	20.66	12.71	8.70	8.23	3.02	4.78	0.81	2.10	0.11
200											19.09	22.72	13.38	9.57	8.66	3.33	5.03	0.89	2.21	0.12
225													15.05	11.90	9.75	4.14	5.66	1.10	2.49	0.15
250													16.73	14.47	10.83	5.03	6.29	1.34	2.77	0.18
275													18.40	17.26	11.92	6.00	6.92	1.60	3.05	0.22
300															13.00	7.05	7.55	1.88	3.32	0.26
325															14.08	8.17	8.18	2.18	3.60	0.30
350															15.17	9.38	8.81	2.50	3.88	0.34
375															16.25	10.65	9.43	2.84	4.15	0.39
400															17.33	12.01	10.06	3.20	4.43	0.44
425															18.42	13.43	10.69	3.58	4.71	0.49
450															19.50	14.93	11.32	3.98	4.99	0.54
475																	11.95	4.40	5.26	0.60
500																	12.58	4.84	5.54	0.66
550																	13.84	5.77	6.10	0.79
600																	15.10	6.78	6.65	0.92

Note: Shaded areas of the chart indicate velocities over 5 feet per second (FPS). Use with caution.

CHARTS

PVC Schedule 80 IPS Plastic Pipe

SIZES: 1/2" through 6"

FLOW: 1 – 600 GPM

PSI LOSS: Per 100' of tube (PSI/100 FT)

C = 150 (1120, 1220)

SIZE	1/2"		3/4"		1"		1 1/4"		1 1/2"		2"		2 1/2"		3"		4"		6"	
OD	0.840		1.050		1.315		1.660		1.900		2.375		2.875		3.500		4.500		6.625	
ID	0.546		0.742		0.957		1.278		1.500		1.939		2.323		2.900		3.826		5.761	
WALL THK.	0.147		0.154		0.179		0.191		0.200		0.218		0.276		0.300		0.337		0.432	
FLOW G. P. M.	Velocity FPS	psi Loss	Velocity FPS	psi Loss	Velocity FPS	psi Loss	Velocity FPS	psi Loss	Velocity FPS	psi Loss	Velocity FPS	psi Loss	Velocity FPS	psi Loss	Velocity FPS	psi Loss	Velocity FPS	psi Loss	Velocity FPS	psi Loss
1	1.36	0.81	0.74	0.18	0.44	0.05	0.24	0.01	0.18	0.01	0.10	0.00								
2	2.73	2.92	1.48	0.66	0.89	0.19	0.49	0.05	0.36	0.02	0.21	0.01	0.15	0.00						
3	4.10	6.19	2.22	1.39	1.33	0.40	0.74	0.10	0.54	0.05	0.32	0.01	0.22	0.01						
4	5.47	10.54	2.96	2.37	1.78	0.69	0.99	0.17	0.72	0.08	0.43	0.02	0.30	0.01						
5	6.84	15.93	3.70	3.58	2.22	1.04	1.24	0.25	0.90	0.12	0.54	0.03	0.37	0.01	0.24	0.00				
6	8.21	22.33	4.44	5.02	2.67	1.46	1.49	0.36	1.08	0.16	0.65	0.05	0.45	0.02	0.29	0.01				
7	9.58	29.71	5.18	6.68	3.11	1.94	1.74	0.47	1.26	0.22	0.75	0.06	0.52	0.03	0.33	0.01				
8	10.94	38.05	5.92	8.56	3.56	2.48	1.99	0.61	1.45	0.28	0.86	0.08	0.60	0.03	0.38	0.01				
9	12.31	47.33	6.66	10.64	4.00	3.09	2.24	0.76	1.63	0.35	0.97	0.10	0.68	0.04	0.43	0.01				
10	13.68	57.52	7.41	12.93	4.45	3.75	2.49	0.92	1.81	0.42	1.08	0.12	0.75	0.05	0.48	0.02	0.27	0.00		
11	15.05	68.63	8.15	15.43	4.90	4.47	2.74	1.10	1.99	0.50	1.19	0.14	0.83	0.06	0.53	0.02	0.30	0.01		
12	16.42	80.63	8.89	18.13	5.34	5.26	2.99	1.29	2.17	0.59	1.30	0.17	0.90	0.07	0.58	0.02	0.33	0.01		
14			10.37	24.12	6.23	6.99	3.49	1.71	2.53	0.79	1.51	0.23	1.05	0.09	0.67	0.03	0.39	0.01		
16			11.85	30.88	7.12	8.95	3.99	2.19	2.90	1.01	1.73	0.29	1.20	0.12	0.77	0.04	0.44	0.01		
18			13.33	38.41	8.01	11.14	4.49	2.73	3.26	1.26	1.95	0.36	1.36	0.15	0.87	0.05	0.50	0.01		
20			14.82	46.69	8.90	13.54	4.99	3.31	3.62	1.52	2.17	0.44	1.51	0.18	0.97	0.06	0.55	0.02		
22			16.30	55.70	9.80	16.15	5.49	3.95	3.98	1.81	2.38	0.52	1.66	0.22	1.06	0.07	0.61	0.02		
24			17.78	65.44	10.69	18.97	5.99	4.64	4.35	2.13	2.60	0.61	1.81	0.25	1.16	0.09	0.66	0.02		
26			19.26	75.90	11.58	22.01	6.49	5.39	4.71	2.47	2.82	0.71	1.96	0.29	1.26	0.10	0.72	0.03		
28					12.47	25.24	6.99	6.18	5.07	2.83	3.03	0.81	2.11	0.34	1.35	0.11	0.78	0.03		
30					13.36	28.69	7.49	7.02	5.43	3.22	3.25	0.92	2.26	0.38	1.45	0.13	0.83	0.03	0.36	0.00
35					15.59	38.16	8.74	9.34	6.34	4.29	3.79	1.23	2.64	0.51	1.69	0.17	0.97	0.05	0.43	0.01
40					17.81	48.87	9.99	11.96	7.25	5.49	4.34	1.57	3.02	0.65	1.94	0.22	1.11	0.06	0.49	0.01
45							11.24	14.88	8.16	6.83	4.88	1.96	3.40	0.81	2.18	0.28	1.25	0.07	0.55	0.01
50							12.49	18.09	9.06	8.30	5.42	2.38	3.78	0.99	2.42	0.34	1.39	0.09	0.61	0.01
55							13.73	21.58	9.97	9.90	5.96	2.84	4.15	1.18	2.66	0.40	1.53	0.10	0.67	0.01
60							14.98	25.35	10.87	11.63	6.51	3.33	4.53	1.38	2.91	0.47	1.67	0.12	0.73	0.02
65							16.23	29.40	11.78	13.49	7.05	3.87	4.91	1.61	3.15	0.55	1.81	0.14	0.79	0.02
70							17.48	33.72	12.69	15.47	7.59	4.44	5.29	1.84	3.39	0.63	1.95	0.16	0.86	0.02
75							18.73	38.32	13.59	17.58	8.13	5.04	5.67	2.09	3.63	0.71	2.09	0.18	0.92	0.03
80							19.98	43.19	14.50	19.81	8.68	5.68	6.04	2.36	3.88	0.80	2.22	0.21	0.98	0.03
85									15.41	22.16	9.22	6.36	6.42	2.63	4.12	0.90	2.36	0.23	1.04	0.03
90									16.32	24.64	9.76	7.07	6.80	2.93	4.36	1.00	2.50	0.26	1.10	0.04
95									17.22	27.23	10.30	7.81	7.18	3.24	4.60	1.10	2.64	0.29	1.16	0.04
100									18.13	29.95	10.85	8.59	7.56	3.57	4.85	1.21	2.78	0.31	1.22	0.04
110									19.94	35.73	11.93	10.25	8.31	4.25	5.33	1.45	3.06	0.38	1.35	0.05
120									13.02	12.04	9.07	5.00	5.82	1.70	3.34	0.44	1.47	0.06		
130									14.10	13.96	9.82	5.60	6.30	1.97	3.62	0.51	1.59	0.07		
140									15.19	16.02	10.58	6.65	6.79	2.27	3.90	0.59	1.72	0.08		
150									16.27	18.20	11.34	7.56	7.27	2.57	4.18	0.67	1.84	0.09		
160									17.36	20.51	12.09	8.51	7.76	2.89	4.45	0.75	1.96	0.10		
170									18.44	22.95	12.85	9.53	8.24	3.24	4.73	0.84	2.08	0.11		
180									19.53	25.51	13.60	10.59	8.73	3.60	5.01	0.93	2.21	0.13		
190									14.36	11.71	9.21	3.98	5.29	1.03	2.33	0.14				
200									15.12	12.87	9.70	4.37	5.57	1.14	2.45	0.16				
225									17.01	16.01	10.91	5.44	6.27	1.41	2.76	0.19				
250									18.90	19.46	12.12	6.61	6.96	1.72	3.07	0.23				
275											13.34	7.89	7.66	2.05	3.38	0.28				
300											14.55	9.27	8.36	2.41	3.68	0.33				
325											15.76	10.75	9.05	2.79	3.99	0.38				
350											16.97	12.33	9.75	3.20	4.30	0.44				
375											18.19	14.01	10.45	3.64	4.60	0.50				
400											19.40	15.79	11.14	4.10	4.91	0.56				
425													11.84	4.59	5.22	0.63				
450															12.54	5.10	5.53	0.70		
475															13.23	5.64	5.83	0.77		
500															13.93	6.20	6.14	0.85		
550															15.32	7.40	6.76	1.01		
600															16.72	8.69	7.37	1.19		

Note: Shaded areas of the chart indicate velocities over 5 feet per second (FPS). Use with caution.

Velocity of flow rate values are computed from the general equation $V = .408 Q/d^2$

Friction pressure loss values are computed from the equation $[hf = 0.2083 (100/C) 1.852 Q^{1.852}/d^{4.868}] \times 4.33$ for psi loss per 100' of pipe.

CHARTS

PVC Class 125 IPS Plastic Pipe

SIZES: 1" through 6"

FLOW: 1 – 600 GPM

PSI LOSS: Per 100' of tube (PSI/100 FT)

C = 150 (1120, 1220) SDR 32.5

SIZE	1"		1 1/4"		1 1/2"		2"		2 1/2"		3"		4"		6"	
OD	1.315		1.660		1.900		2.375		2.875		3.500		4.500		6.625	
ID	1.211		1.548		1.784		2.229		2.699		3.284		4.224		6.217	
WALL THK.	0.052		0.056		0.058		0.073		0.088		0.108		0.138		0.204	
FLOW G. P. M.	Velocity FPS	psi Loss	Velocity FPS	psi Loss	Velocity FPS	psi Loss	Velocity FPS	psi Loss	Velocity FPS	psi Loss	Velocity FPS	psi Loss	Velocity FPS	psi Loss	Velocity FPS	psi Loss
1	0.27	0.02	0.17	0.01	0.12	0.00										
2	0.55	0.06	0.34	0.02	0.25	0.01	0.16	0.00								
3	0.83	0.13	0.51	0.04	0.38	0.02	0.24	0.01								
4	1.11	0.22	0.68	0.07	0.51	0.03	0.32	0.01	0.22	0.00						
5	1.39	0.33	0.85	0.10	0.64	0.05	0.41	0.02	0.28	0.01						
6	1.66	0.46	1.02	0.14	0.76	0.07	0.49	0.02	0.33	0.01						
7	1.94	0.62	1.19	0.19	0.89	0.09	0.57	0.03	0.39	0.01	0.26	0.00				
8	2.22	0.79	1.36	0.24	1.02	0.12	0.65	0.04	0.44	0.02	0.30	0.01				
9	2.50	0.98	1.53	0.30	1.15	0.15	0.73	0.05	0.50	0.02	0.34	0.01				
10	2.78	1.19	1.70	0.36	1.28	0.18	0.82	0.06	0.56	0.02	0.37	0.01				
11	3.06	1.42	1.87	0.43	1.41	0.22	0.90	0.07	0.61	0.03	0.41	0.01				
12	3.33	1.67	2.04	0.51	1.53	0.25	0.98	0.09	0.67	0.03	0.45	0.01	0.27	0.00		
14	3.89	2.22	2.38	0.67	1.79	0.34	1.14	0.11	0.78	0.05	0.52	0.02	0.32	0.01		
16	4.45	2.85	2.72	0.86	2.05	0.43	1.31	0.15	0.89	0.06	0.60	0.02	0.36	0.01		
18	5.00	3.54	3.06	1.07	2.30	0.54	1.47	0.18	1.00	0.07	0.68	0.03	0.41	0.01		
20	5.56	4.31	3.40	1.30	2.56	0.65	1.64	0.22	1.12	0.09	0.75	0.03	0.45	0.01		
22	6.12	5.14	3.74	1.56	2.82	0.78	1.80	0.26	1.23	0.10	0.83	0.04	0.50	0.01		
24	6.67	6.04	4.08	1.83	3.07	0.92	1.97	0.31	1.34	0.12	0.90	0.05	0.54	0.01		
26	7.23	7.00	4.42	2.12	3.33	1.06	2.13	0.36	1.45	0.14	0.98	0.05	0.59	0.02		
28	7.78	8.03	4.76	2.43	3.58	1.22	2.29	0.41	1.56	0.16	1.05	0.06	0.644	0.02		
30	8.34	9.13	5.10	2.76	3.84	1.39	2.46	0.47	1.68	0.18	1.13	0.07	0.68	0.02		
35	9.73	12.14	5.95	3.68	4.48	1.84	2.87	0.62	1.96	0.25	1.32	0.09	0.80	0.03	0.36	0.00
40	11.12	15.55	6.81	4.71	5.12	2.36	3.28	0.80	2.24	0.31	1.51	0.12	0.91	0.04	0.42	0.01
45	12.51	19.34	7.66	5.86	5.76	2.94	3.69	0.99	2.52	0.39	1.70	0.15	1.02	0.04	0.47	0.01
50	13.91	23.50	8.51	7.12	6.40	3.57	4.10	1.21	2.80	0.48	1.89	0.18	1.14	0.05	0.52	0.01
55	15.30	28.04	9.36	8.49	7.05	4.26	4.51	1.44	3.08	0.57	2.08	0.22	1.25	0.06	0.58	0.01
60	16.69	32.94	10.21	9.98	7.69	5.00	4.92	1.69	3.36	0.67	2.26	0.26	1.37	0.085	0.63	0.01
65	18.08	38.21	11.06	11.57	8.33	5.80	5.33	1.96	3.64	0.77	2.45	0.30	1.48	0.09	0.68	0.01
70	19.47	43.83	11.91	13.27	8.97	6.65	5.74	2.25	3.92	0.89	2.64	0.34	1.60	0.10	0.73	0.02
75			12.76	15.08	9.61	7.56	6.15	2.56	4.20	1.01	2.83	0.39	1.71	0.11	0.79	0.02
80			13.62	17.00	10.25	8.52	6.56	2.88	4.48	1.14	3.02	0.44	1.82	0.13	0.84	0.02
85			14.47	19.02	10.89	9.53	6.98	3.23	4.76	1.27	3.21	0.49	1.94	0.14	0.89	0.02
90			15.32	21.14	11.53	10.60	7.39	3.59	5.04	1.41	3.40	0.54	2.05	0.16	0.95	0.02
95			16.17	23.37	12.17	11.71	7.80	3.96	5.32	1.56	3.59	0.60	2.17	0.18	1.00	0.03
100			17.02	25.69	12.81	12.88	8.21	4.36	5.60	1.72	3.78	0.66	2.28	0.19	1.05	0.03
110			18.72	3.65	14.10	15.37	9.03	5.20	6.16	2.05	4.16	0.79	2.51	0.23	1.16	0.04
120					15.38	18.06	9.85	6.11	6.72	2.41	4.53	0.93	2.74	0.27	1.26	0.04
130					16.66	20.94	10.67	7.09	7.28	2.79	4.91	1.08	2.97	0.32	1.37	0.05
140					17.94	24.02	11.49	8.13	7.84	3.20	5.29	1.23	3.20	0.36	1.47	0.06
150					19.22	27.30	12.31	9.24	8.40	3.64	5.67	1.40	3.43	0.41	1.58	0.06
160							13.13	10.41	8.96	4.10	6.05	1.58	3.65	0.46	1.68	0.07
170							13.96	11.65	9.52	4.59	6.43	1.77	3.88	0.52	1.79	0.08
180							14.78	12.95	10.08	5.10	6.80	1.96	4.11	0.58	1.90	0.09
190							15.60	14.31	10.64	5.64	7.18	2.17	4.34	0.64	2.00	0.10
200							16.42	15.74	11.20	6.20	7.56	2.39	4.57	0.70	2.11	0.11
225							18.47	19.57	12.60	7.72	8.51	2.97	5.14	0.87	2.37	0.13
250									14.00	9.38	9.45	3.61	5.71	1.06	2.63	0.16
275									15.40	11.19	10.40	4.31	6.28	1.27	2.90	0.19
300									16.80	13.15	11.34	5.06	6.86	1.49	3.16	0.23
325									18.20	15.25	12.29	5.87	7.43	1.72	3.43	0.26
350									19.60	17.49	13.24	6.73	8.00	1.98	3.69	0.30
375											14.18	7.65	8.57	2.25	3.95	0.34
400											15.13	8.62	9.14	2.53	4.22	0.39
425											16.07	9.65	9.71	2.83	4.48	0.43
450											17.02	10.72	10.29	3.15	4.75	0.48
475											17.96	11.85	10.86	3.48	5.01	0.53
500											18.91	13.03	11.43	3.83	5.27	0.58
550													12.57	4.57	5.80	0.70
600													13.72	5.37	6.33	0.82

Note: Shaded areas of the chart indicate velocities over 5 feet per second (FPS). Use with caution.

CHARTS

PVC Class 160 IPS Plastic Pipe

SIZES: 1" through 6"

FLOW: 1 – 600 GPM

PSI LOSS: Per 100' of tube (PSI/100 FT)

C = 150 (1120, 1220) SDR 26

SIZE	1"		1 1/4"		1 1/2"		2"		2 1/2"		3"		4"		6"	
OD	1.315	1.660	1.900	2.375	2.875	3.500	4.500	6.625								
ID	1.195	1.532	1.754	2.193	2.655	3.230	4.154	6.115								
WALL THK.	0.060	0.064	0.073	0.091	0.110	0.135	0.173	0.225								
FLOW G. P. M.	Velocity FPS	psi Loss	Velocity FPS	psi Loss	Velocity FPS	psi Loss	Velocity FPS	psi Loss	Velocity FPS	psi Loss	Velocity FPS	psi Loss	Velocity FPS	psi Loss	Velocity FPS	psi Loss
1	0.28	0.02	0.17	0.01	0.13	0.00										
2	0.57	0.06	0.34	0.02	0.26	0.01	0.16	0.00								
3	0.85	0.14	0.52	0.04	0.39	0.02	0.25	0.01								
4	1.14	0.23	0.69	0.07	0.53	0.04	0.33	0.01	0.23	0.00						
5	1.42	0.35	0.86	0.11	0.66	0.05	0.42	0.02	0.28	0.01						
6	1.71	0.49	1.04	0.15	0.79	0.08	0.50	0.03	0.34	0.01	0.20	0.00				
7	1.99	0.66	1.21	0.20	0.92	0.10	0.59	0.03	0.40	0.01	0.27	0.01				
8	2.28	0.84	1.39	0.25	1.06	0.13	0.67	0.04	0.46	0.02	0.31	0.01				
9	2.57	1.05	1.56	0.31	1.19	0.16	0.76	0.05	0.52	0.02	0.35	0.01				
10	2.85	1.27	1.73	0.38	1.32	0.20	0.84	0.07	0.57	0.03	0.39	0.01				
11	3.14	1.52	1.91	0.45	1.45	0.23	0.93	0.08	0.63	0.03	0.43	0.01				
12	3.42	1.78	2.085	0.53	1.59	0.28	1.01	0.09	0.69	0.04	0.46	0.01	0.28	0.00		
14	3.99	2.37	2.43	0.71	1.85	0.37	1.18	0.12	0.81	0.05	0.54	0.02	0.33	0.01		
16	4.57	3.04	2.78	0.91	2.12	0.47	1.35	0.16	0.92	0.06	0.62	0.02	0.37	0.01		
18	5.14	3.78	3.12	1.13	2.38	0.58	1.52	0.20	1.04	0.08	0.70	0.03	0.42	0.01		
20	5.71	4.59	3.47	1.37	2.65	0.71	1.69	0.24	1.15	0.09	0.78	0.04	0.47	0.01		
22	6.28	5.48	3.82	1.64	2.91	0.85	1.86	0.29	1.27	0.11	0.86	0.04	0.52	0.01		
24	6.85	6.44	4.17	1.92	3.18	1.00	2.03	0.34	1.38	0.13	0.93	0.05	0.56	0.02		
26	7.42	7.47	4.51	2.23	3.44	1.15	2.20	0.39	1.50	0.15	1.01	0.06	0.61	0.02		
28	7.99	8.57	4.86	2.56	3.71	1.32	2.37	0.45	1.62	0.18	1.09	0.07	0.66	0.02		
30	8.57	9.74	5.21	2.91	3.97	1.50	2.54	0.51	1.73	0.20	1.17	0.08	0.70	0.02		
35	9.99	12.95	6.08	3.87	4.64	2.00	2.96	0.68	2.02	0.27	1.36	0.10	0.82	0.03	0.38	0.00
40	11.42	16.59	6.95	4.95	5.30	2.56	3.39	0.86	2.31	0.34	1.56	0.13	0.94	0.04	0.43	0.01
45	12.85	20.63	7.82	6.16	5.96	3.19	3.81	1.08	2.60	0.42	1.75	0.16	1.06	0.05	0.49	0.01
50	14.28	25.07	8.69	7.49	6.63	3.88	4.24	1.31	2.89	0.52	1.95	0.20	1.18	0.06	0.54	0.01
55	15.71	29.91	9.56	8.93	7.29	4.62	4.66	1.56	3.18	0.62	2.15	0.24	1.30	0.07	0.60	0.01
60	17.14	35.14	10.43	10.49	7.95	5.43	5.09	1.83	3.47	0.72	2.34	0.28	1.41	0.08	0.65	0.01
65	18.57	40.67	11.29	12.17	8.62	6.30	5.51	2.12	3.76	0.84	2.54	0.32	1.53	0.09	0.70	0.01
70	19.99	46.76	12.16	13.96	9.28	7.23	5.93	2.44	4.05	0.96	2.73	0.37	1.65	0.11	0.76	0.02
75			13.03	15.86	9.94	8.21	6.36	2.77	4.34	1.09	2.93	0.42	1.77	0.12	0.81	0.02
80			13.90	17.88	10.60	9.25	6.78	3.12	4.63	1.23	3.12	0.47	1.89	0.14	0.87	0.02
85			14.77	20.00	11.27	10.35	7.21	3.49	4.91	1.38	3.32	0.53	2.00	0.16	0.92	0.02
90			15.64	22.23	11.93	11.51	7.63	3.88	5.20	1.53	3.51	0.59	2.12	0.17	0.98	0.03
95			16.51	24.58	12.59	12.72	8.05	4.29	5.49	1.69	3.71	0.65	2.24	0.19	1.03	0.03
100			17.38	27.03	13.26	13.99	8.48	4.72	5.78	1.86	3.91	0.72	2.36	0.21	1.09	0.03
110			19.12	32.24	14.58	16.69	9.33	5.63	6.36	2.22	4.30	0.86	2.60	0.25	1.20	0.04
120					15.91	19.61	10.18	6.61	6.94	2.61	4.69	1.01	2.83	0.30	1.30	0.05
130					17.24	22.74	11.02	7.67	7.52	3.03	5.08	1.17	3.07	0.34	1.41	0.05
140					18.56	26.09	11.87	8.80	8.10	3.47	5.47	1.34	3.31	0.39	1.52	0.06
150					19.89	29.64	12.72	10.00	8.68	3.94	5.86	1.52	3.54	0.45	1.63	0.07
160							13.57	11.27	9.26	4.45	6.25	1.71	3.78	0.50	1.74	0.08
170							14.42	12.61	9.83	4.97	6.64	1.92	4.01	0.56	1.85	0.09
180							15.27	14.02	10.41	5.53	7.03	2.13	4.25	0.63	1.96	0.10
190							16.11	15.49	10.99	6.11	7.43	2.35	4.49	0.69	2.07	0.11
200							16.96	17.03	11.57	6.72	7.82	2.59	4.72	0.76	2.18	0.12
225							19.08	21.19	13.02	8.36	8.79	3.22	5.31	0.95	2.45	0.14
250									14.47	10.16	9.77	3.91	5.91	1.15	2.72	0.18
275									15.91	12.12	10.75	4.67	6.50	1.37	3.00	0.21
300									17.36	14.24	11.73	5.49	7.09	1.61	3.27	0.25
325									18.81	16.51	12.70	6.36	7.68	1.87	3.54	0.29
350											13.68	7.30	8.27	2.15	3.81	0.33
375											14.66	8.29	8.86	2.44	4.09	0.37
400											15.64	9.35	9.45	2.75	4.36	0.42
425											16.62	10.46	10.04	3.07	4.63	0.47
450											17.59	11.62	10.63	3.42	4.90	0.52
475											18.57	12.85	11.23	3.78	5.18	0.58
500											19.55	14.13	11.82	4.15	5.45	0.63
550													13.00	4.96	6.00	0.76
600													14.18	5.82	6.54	0.89

Note: Shaded areas of the chart indicate velocities over 5 feet per second (FPS). Use with caution.

CHARTS

PVC Class 200 IPS Plastic Pipe

SIZES: 3/4" through 6"

FLOW: 1 – 600 GPM

PSI LOSS: Per 100' of pipe (PSI/100 FT)

C = 150 (1120, 1220) SDR 21

SIZE	3/4"	1"	1 1/4"	1 1/2"	2"	2 1/2"	3"	4"	6"									
OD	1.050	1.315	1.660	1.900	2.375	2.875	3.500	4.500	6.625									
ID	0.930	1.189	1.502	1.720	2.149	2.601	3.166	4.072	5.993									
WALL THK.	0.060	0.063	0.079	0.090	0.113	0.137	0.167	0.214	0.316									
FLOW G. P. M.	Velocity FPS	psi Loss	Velocity FPS	psi Loss	Velocity FPS	psi Loss	Velocity FPS	psi Loss	Velocity FPS	psi Loss	Velocity FPS	psi Loss	Velocity FPS	psi Loss	Velocity FPS	psi Loss	Velocity FPS	psi Loss
1	0.47	0.06	0.28	0.02	0.18	0.01	0.13	0.00										
2	0.94	0.22	0.57	0.07	0.36	0.02	0.27	0.01	0.17	0.00								
3	1.42	0.46	0.86	0.14	0.54	0.04	0.41	0.02	0.26	0.01	0.18	0.00						
4	1.89	0.79	1.15	0.24	0.72	0.08	0.55	0.04	0.35	0.01	0.24	0.01						
5	2.36	1.20	1.44	0.36	0.90	0.12	0.68	0.06	0.44	0.02	0.30	0.01						
6	2.83	1.68	1.73	0.51	1.08	0.16	0.82	0.08	0.53	0.03	0.36	0.01	0.24	0.00				
7	3.30	2.23	2.02	0.67	1.26	0.22	0.96	0.11	0.61	0.04	0.42	0.01	0.28	0.01				
8	3.77	2.85	2.30	0.86	1.44	0.28	1.10	0.14	0.70	0.05	0.48	0.02	0.32	0.01				
9	4.25	3.55	2.59	1.07	1.62	0.34	1.24	0.18	0.79	0.06	0.54	0.02	0.36	0.01				
10	4.72	4.31	2.88	1.30	1.80	0.42	1.37	0.22	0.88	0.07	0.60	0.03	0.40	0.01				
11	5.19	5.15	3.17	1.56	1.98	0.50	1.51	0.26	0.97	0.09	0.66	0.03	0.44	0.01				
12	5.66	6.05	3.46	1.83	2.17	0.59	1.65	0.30	1.06	0.10	0.72	0.04	0.48	0.02	0.29	0.00		
14	6.60	8.05	4.04	2.43	2.53	0.78	1.93	0.40	1.23	0.14	0.84	0.05	0.56	0.02	0.34	0.01		
16	7.55	10.30	4.61	3.11	2.89	1.00	2.20	0.52	1.41	0.17	0.96	0.07	0.65	0.03	0.39	0.01		
18	8.49	12.81	5.19	3.87	3.25	1.24	2.48	0.64	1.59	0.22	1.08	0.09	0.73	0.03	0.44	0.01		
20	9.43	15.58	5.77	4.71	3.61	1.51	2.75	0.78	1.76	0.26	1.20	0.10	0.81	0.04	0.49	0.01		
22	10.38	18.58	6.34	5.62	3.97	1.80	3.03	0.93	1.94	0.32	1.32	0.12	0.89	0.05	0.54	0.01		
24	11.32	21.83	6.92	6.60	4.34	2.12	3.30	1.09	2.12	0.37	1.44	0.15	0.97	0.06	0.59	0.02		
26	12.27	25.32	7.50	7.65	4.70	2.46	3.58	1.27	2.29	0.43	1.56	0.17	1.05	0.07	0.63	0.02		
28	13.21	29.04	8.08	8.78	5.06	2.82	3.86	1.46	2.47	0.49	1.68	0.19	1.13	0.07	0.68	0.02		
30	14.15	33.00	8.65	9.98	5.42	3.20	4.13	1.66	2.65	0.56	1.80	0.22	1.22	0.09	0.73	0.02	0.34	0.00
35	16.51	43.91	10.10	13.27	6.32	4.26	4.82	2.20	3.09	0.75	2.11	0.29	1.42	0.11	0.86	0.03	0.39	0.01
40	18.87	56.23	11.54	17.00	7.23	5.45	5.51	2.82	3.53	0.95	2.41	0.38	1.62	0.14	0.98	0.04	0.45	0.01
45			12.98	21.14	8.13	6.78	6.20	3.51	3.97	1.19	2.71	0.47	1.83	0.18	1.10	0.05	0.51	0.01
50			14.42	25.70	9.04	8.24	6.89	4.26	4.41	1.44	3.01	0.57	2.03	0.22	1.23	0.06	0.56	0.01
55			15.87	30.66	9.94	9.83	7.58	5.09	4.85	1.72	3.31	0.68	2.23	0.26	1.35	0.08	0.62	0.01
60			17.31	36.02	10.85	11.55	8.27	5.97	5.30	2.02	3.61	0.80	2.44	0.31	1.47	0.09	0.68	0.01
65			18.75	41.77	11.75	13.40	8.96	6.93	5.74	2.35	3.92	0.93	2.64	0.36	1.59	0.10	0.73	0.02
70					12.65	15.37	9.65	7.95	6.18	2.69	4.22	1.06	2.84	0.41	1.72	0.12	0.79	0.02
75					13.56	17.47	10.34	9.03	6.62	3.06	4.52	1.21	3.05	0.46	1.84	0.14	0.85	0.02
80					14.46	19.68	11.03	10.18	7.06	3.44	4.82	1.36	3.25	0.52	1.96	0.15	0.90	0.02
85					15.37	22.02	11.72	11.39	7.50	3.85	5.12	1.52	3.45	0.59	2.09	0.17	0.96	0.03
90					16.27	24.48	12.41	12.66	7.95	4.28	5.42	1.69	3.66	0.65	2.21	0.19	1.02	0.03
95					17.18	27.06	13.10	13.99	8.39	4.74	5.72	1.87	3.86	0.72	2.33	0.21	1.07	0.03
100					18.08	29.76	13.79	15.39	8.83	5.21	6.03	2.06	4.07	0.79	2.46	0.23	1.13	0.04
110					19.89	35.50	15.17	18.36	9.71	6.21	6.63	2.45	4.47	0.94	2.70	0.28	1.24	0.04
120							16.54	21.57	10.60	7.30	7.23	2.88	4.88	1.11	2.95	0.33	1.36	0.05
130							17.92	25.02	11.48	8.47	7.84	3.34	5.29	1.29	3.19	0.38	1.47	0.06
140							19.30	28.70	12.36	9.71	8.44	3.84	5.69	1.47	3.44	0.43	1.59	0.07
150									13.25	11.04	9.04	4.36	6.10	1.68	3.69	0.49	1.70	0.08
160									14.13	12.44	9.64	4.91	6.51	1.89	3.93	0.55	1.81	0.08
170									15.01	13.91	10.25	5.50	6.91	2.11	4.18	0.62	1.93	0.09
180									15.90	15.47	10.85	6.11	7.32	2.35	4.42	0.69	2.04	0.11
190									16.78	17.10	11.45	6.75	7.73	2.60	4.67	0.76	2.15	0.12
200									17.66	18.80	12.06	7.43	8.14	2.85	4.92	0.84	2.27	0.13
225									19.87	23.38	13.56	9.24	9.15	3.55	5.53	1.04	2.55	0.16
250											15.07	11.23	10.17	4.31	6.15	1.27	2.83	0.19
275											16.58	13.39	11.19	5.15	6.76	1.51	3.12	0.23
300											18.09	15.74	12.21	6.05	7.38	1.78	3.40	0.27
325											19.60	18.25	13.22	7.01	7.99	2.06	3.69	0.31
350													14.24	8.05	8.61	2.36	3.97	0.36
375													15.26	9.14	9.22	2.69	4.25	0.41
400													16.28	10.30	9.84	3.03	4.54	0.46
425													17.29	11.53	10.45	3.396	4.82	0.52
450													18.31	12.81	11.07	3.77	5.11	0.57
475													19.33	14.16	11.68	4.16	5.39	0.63
500															12.30	4.58	5.67	0.70
550															13.53	5.46	6.24	0.83
600															14.76	6.42	6.81	0.98

Note: Shaded areas of the chart indicate velocities over 5 feet per second (FPS). Use with caution.

CHARTS

PVC Class 315 IPS Plastic Pipe

SIZES: 1/2" through 6"

FLOW: 1 – 600 GPM

PSI LOSS: Per 100' of pipe (PSI/100 FT)

C = 150 (1120, 1220) SDR 13.5

SIZE	1/2"		3/4"		1"		1 1/4"		1 1/2"		2"		2 1/2"		3"		4"		6"	
OD	0.840		1.050		1.315		1.660		1.900		2.375		2.875		3.500		4.500		6.625	
ID	0.716		0.894		1.121		1.414		1.618		2.023		2.449		2.982		3.834		5.643	
WALL THK.	0.062		0.078		0.097		0.123		0.141		0.176		0.213		0.259		0.333		0.491	
FLOW G. P. M.	Velocity FPS	psi Loss	Velocity FPS	psi Loss	Velocity FPS	psi Loss	Velocity FPS	psi Loss	Velocity FPS	psi Loss	Velocity FPS	psi Loss	Velocity FPS	psi Loss	Velocity FPS	psi Loss	Velocity FPS	psi Loss	Velocity FPS	psi Loss
1	0.79	0.22	0.51	0.07	0.32	0.02	0.20	0.01	0.15	0.00										
2	1.59	0.78	1.02	0.27	0.64	0.09	0.40	0.03	0.31	0.01	0.19	0.00								
3	2.38	1.65	1.53	0.56	0.97	0.19	0.61	0.06	0.46	0.03	0.29	0.01	0.20	0.00						
4	3.18	2.82	2.04	0.96	1.29	0.32	0.81	0.10	0.62	0.05	0.39	0.02	0.27	0.01						
5	3.97	4.26	2.55	1.45	1.62	0.48	1.02	0.16	0.77	0.08	0.49	0.03	0.34	0.01	0.22	0.00				
6	4.77	5.97	3.06	2.03	1.94	0.67	1.22	0.22	0.93	0.11	0.59	0.04	0.40	0.02	0.27	0.01				
7	5.57	7.95	3.57	2.70	2.27	0.90	1.42	0.29	1.09	0.15	0.69	0.05	0.47	0.02	0.32	0.01				
8	6.36	10.18	4.08	3.45	2.59	1.15	1.63	0.37	1.24	0.19	0.79	0.06	0.54	0.03	0.36	0.01				
9	7.16	12.66	4.59	4.30	2.92	1.43	1.83	0.46	1.40	0.24	0.89	0.08	0.61	0.03	0.41	0.01				
10	7.95	15.38	5.10	5.22	3.24	1.74	2.04	0.56	1.55	0.29	0.99	0.10	0.68	0.04	0.45	0.01	0.27	0.00		
11	8.75	18.35	5.61	6.23	3.57	2.07	2.24	0.67	1.71	0.35	1.09	0.12	0.74	0.05	0.50	0.02	0.30	0.01		
12	9.55	21.56	6.12	7.32	3.89	2.43	2.44	0.79	1.87	0.41	1.19	0.14	0.81	0.05	0.55	0.02	0.33	0.01		
14	11.14	28.69	7.14	9.74	4.54	3.24	2.85	1.05	2.18	0.54	1.39	0.18	0.95	0.07	0.64	0.03	0.38	0.01		
16	12.73	36.74	8.16	12.47	5.19	4.15	3.26	1.34	2.49	0.70	1.59	0.23	1.08	0.09	0.73	0.04	0.44	0.01		
18	14.32	45.69	9.18	15.51	5.84	5.16	3.67	1.67	2.80	0.87	1.79	0.29	1.22	0.12	0.82	0.04	0.49	0.01		
20	15.91	55.54	10.20	18.86	6.49	6.27	4.08	2.03	3.11	1.05	1.99	0.35	1.36	0.14	0.91	0.05	0.55	0.02		
22	17.50	66.26	11.23	22.50	7.14	7.48	4.48	2.42	3.42	1.25	2.19	0.42	1.49	0.17	1.00	0.06	0.61	0.02		
24	19.10	77.84	12.25	26.43	7.79	8.79	4.89	2.84	3.74	1.47	2.39	0.50	1.63	0.20	1.10	0.08	0.66	0.02		
26			13.27	30.65	8.44	10.19	5.30	3.29	4.05	1.71	2.59	0.58	1.76	0.23	1.19	0.09	0.72	0.03		
28			14.29	35.16	9.09	11.69	5.71	3.78	4.36	1.96	2.79	0.66	1.90	0.26	1.28	0.10	0.77	0.03	0.35	0.00
30			15.31	39.95	9.74	13.29	6.12	4.29	4.67	2.23	2.99	0.75	2.04	0.30	1.37	0.11	0.83	0.03	0.38	0.01
35			17.86	53.15	11.36	17.68	7.14	5.71	5.45	2.96	3.48	1.00	2.38	0.39	1.60	0.15	0.97	0.04	0.44	0.01
40					12.98	22.64	8.16	7.31	6.23	3.80	3.98	1.28	2.72	0.51	1.83	0.19	1.11	0.06	0.51	0.01
45					14.61	28.15	9.18	9.10	7.01	4.72	4.48	1.59	3.06	0.63	2.06	0.24	1.24	0.07	0.57	0.01
50					16.23	34.22	10.20	11.06	7.79	5.74	4.98	1.94	3.40	0.76	2.29	0.29	1.38	0.09	0.64	0.01
55					17.85	40.83	11.22	13.19	8.57	6.85	5.48	2.31	3.74	0.91	2.52	0.35	1.52	0.10	0.70	0.02
60					19.48	47.97	12.24	15.50	9.35	8.04	5.98	2.71	4.08	1.07	2.75	0.41	1.66	0.12	0.76	0.02
65							13.26	17.97	10.13	9.33	6.48	3.15	4.42	1.24	2.98	0.48	1.80	0.14	0.83	0.02
70							14.28	20.62	10.90	10.70	6.97	3.61	4.76	1.42	3.21	0.55	1.94	0.16	0.89	0.02
75							15.30	23.43	11.68	12.16	7.47	4.10	5.10	1.62	3.44	0.62	2.08	0.18	0.96	0.03
80							16.32	26.40	12.46	13.71	7.97	4.62	5.44	1.82	3.67	0.70	2.22	0.21	1.02	0.03
85							17.34	29.54	13.24	15.33	8.47	5.17	5.78	2.04	3.89	0.78	2.35	0.23	1.08	0.04
90							18.36	32.84	14.02	17.05	8.97	5.75	6.12	2.27	4.12	0.87	2.49	0.26	1.15	0.04
95							19.38	36.30	14.80	18.84	9.47	6.35	6.46	2.51	4.35	0.96	2.63	0.28	1.21	0.04
100									15.58	20.72	9.96	6.99	6.80	2.76	4.58	1.06	2.77	0.31	1.28	0.05
110									17.14	24.72	10.96	8.34	7.48	3.29	5.04	1.26	3.05	0.37	1.40	0.06
120									18.70	29.04	11.96	9.79	8.16	3.87	5.50	1.48	3.33	0.44	1.53	0.07
130											12.96	11.36	8.84	4.48	5.96	1.72	3.60	0.51	1.66	0.08
140											13.95	13.03	9.52	5.14	6.42	1.97	3.88	0.58	1.79	0.09
150											14.95	14.81	10.20	5.84	6.88	2.24	4.16	0.66	1.92	0.10
160											15.95	16.69	10.88	6.59	7.34	2.53	4.44	0.74	2.04	0.11
170											16.94	18.67	11.56	7.37	7.79	2.83	4.71	0.83	2.17	0.13
180											17.94	20.75	12.24	8.19	8.25	3.14	4.99	0.93	2.30	0.14
190											18.94	22.94	12.92	9.05	8.71	3.47	5.27	1.02	2.43	0.16
200											19.93	25.23	13.60	9.95	9.17	3.82	5.55	1.12	2.56	0.17
225													15.30	12.38	10.32	4.75	6.24	1.40	2.88	0.21
250													17.00	15.05	11.47	5.77	6.93	1.70	3.20	0.26
275													18.70	17.95	12.61	6.89	7.63	2.03	3.52	0.31
300															13.76	8.09	8.32	2.38	3.84	0.36
325															14.91	9.39	9.02	2.76	4.16	0.42
350															16.05	10.77	9.71	3.17	4.48	0.48
375															17.20	12.23	10.40	3.60	4.80	0.55
400															18.35	13.79	11.10	4.06	5.12	0.62
425															19.49	15.42	11.79	4.54	5.44	0.69
450																	12.49	5.05	5.76	0.77
475																	13.18	5.58	6.08	0.85
500																	13.87	6.14	6.40	0.94
550																	15.26	7.32	7.04	1.12
600																	16.65	8.60	7.68	1.31

Note: Shaded areas of the chart indicate velocities over 5 feet per second (FPS). Use with caution.

CHARTS

Type K Copper Water Tube

SIZES: 1/2" through 3"

FLOW: 1 – 600 GPM

PSI LOSS: Per 100' of tube (PSI/100 FT)

C = 140

SIZE	1/2"		5/8"		3/4"		1"		1 1/4"		1 1/2"		2"		2 1/2"		3"	
OD	0.625		0.750		0.875		1.125		1.375		1.625		2.125		2.625		3.125	
ID	0.527		0.652		0.745		0.995		1.245		1.481		1.959		2.435		2.907	
WALL THK.	0.049		0.049		0.065		0.065		0.065		0.072		0.083		0.095		0.109	
FLOW G. P. M.	Velocity FPS	psi Loss	Velocity FPS	psi Loss	Velocity FPS	psi Loss	Velocity FPS	psi Loss	Velocity FPS	psi Loss	Velocity FPS	psi Loss	Velocity FPS	psi Loss	Velocity FPS	psi Loss	Velocity FPS	psi Loss
1	1.45	1.09	0.95	0.39	0.73	0.20	0.41	0.05	0.26	0.02	0.18	0.01	0.10	0.00				
2	2.93	3.94	1.91	1.40	1.47	0.73	0.82	0.18	0.52	0.06	0.37	0.03	0.21	0.01				
3	4.40	8.35	2.87	2.974	2.20	1.55	1.23	0.38	0.78	0.13	0.55	0.05	0.31	0.01	0.20	0.00		
4	5.87	14.23	3.83	5.05	2.94	2.64	1.64	0.65	1.05	0.22	0.74	0.09	0.42	0.02	0.27	0.01	0.19	0.00
5	7.34	21.51	4.79	7.64	3.67	3.99	2.06	0.98	1.31	0.33	0.93	0.14	0.53	0.04	0.34	0.01	0.24	0.01
6	8.81	30.15	5.75	10.70	4.41	5.60	2.47	1.37	1.57	0.46	1.11	0.20	0.63	0.05	0.41	0.02	0.28	0.01
7	10.28	40.11	6.71	14.24	5.14	7.44	2.88	1.82	1.84	0.61	1.30	0.26	0.74	0.07	0.48	0.02	0.33	0.01
8	11.75	51.37	7.67	18.24	5.88	9.53	3.29	2.33	2.10	0.78	1.48	0.34	0.85	0.09	0.55	0.03	0.38	0.01
9	13.22	63.89	8.63	22.68	6.61	11.86	3.70	2.90	2.36	0.97	1.67	0.42	0.95	0.11	0.61	0.04	0.43	0.02
10	14.69	77.66	9.59	27.57	7.35	14.41	4.12	3.53	2.63	1.18	1.86	0.51	1.06	0.13	0.68	0.05	0.48	0.02
11	16.15	92.65	10.55	32.89	8.08	17.19	4.53	4.21	2.89	1.41	2.04	0.61	1.16	0.16	0.75	0.05	0.53	0.02
12	17.62	108.85	11.51	38.64	8.82	20.20	4.94	4.94	3.15	1.66	2.23	0.71	1.27	0.18	0.82	0.06	0.57	0.03
14			13.43	51.41	10.29	26.87	5.76	6.57	3.68	2.21	2.60	0.95	1.48	0.24	0.95	0.08	0.67	0.04
16			15.35	65.83	11.76	34.41	6.59	8.42	4.21	2.83	2.97	1.22	1.70	0.31	1.10	0.11	0.77	0.05
18			17.27	81.88	13.23	42.80	7.41	10.47	4.73	3.52	3.34	1.51	1.91	0.39	1.23	0.13	0.86	0.06
20			19.19	99.53	14.70	52.02	8.24	12.73	5.26	4.28	3.72	1.84	2.12	0.47	1.37	0.16	0.96	0.07
22					16.17	62.06	9.06	15.18	5.79	5.10	4.09	2.19	2.33	0.56	1.51	0.20	1.06	0.08
24					17.64	72.92	9.89	17.84	6.31	5.99	4.46	2.58	2.55	0.66	1.65	0.23	1.15	0.10
26					19.11	84.57	10.71	20.69	6.84	6.95	4.83	2.99	2.76	0.77	1.78	0.27	1.25	0.11
28							11.53	23.73	7.37	7.98	5.20	3.43	2.97	0.88	1.92	0.30	1.35	0.13
30							12.36	26.97	7.89	9.06	5.58	3.89	3.18	1.00	2.06	0.35	1.44	0.15
35							14.42	35.88	9.21	12.06	6.51	5.18	3.72	1.33	2.40	0.46	1.68	0.19
40							16.48	45.95	10.52	15.44	7.44	6.63	4.25	1.70	2.75	0.59	1.93	0.25
45							18.54	57.15	11.84	19.20	8.37	8.25	4.78	2.12	3.00	0.73	2.17	0.31
50									13.16	23.34	9.30	10.03	5.31	2.57	3.44	0.89	2.41	0.38
55									14.47	27.85	10.23	11.97	5.84	3.07	3.78	1.06	2.65	0.45
60									15.79	32.71	11.16	14.06	6.37	3.60	4.12	1.25	2.89	0.53
65									17.10	37.94	12.09	16.31	6.91	4.18	4.47	1.45	3.13	0.61
70									18.42	43.52	13.02	18.70	7.44	4.80	4.81	1.66	3.37	0.70
75									19.74	49.45	13.95	21.25	7.97	5.45	5.16	1.89	3.62	0.80
80											14.88	23.95	8.50	6.14	5.50	2.13	3.86	0.90
85											15.81	26.80	9.03	6.87	5.84	2.38	4.10	1.01
90											16.74	29.79	9.56	7.64	6.19	2.65	4.34	1.12
95											17.67	32.93	10.09	8.44	6.53	2.93	4.58	1.24
100											18.60	36.21	10.63	9.28	6.88	3.22	4.82	1.36
110													11.69	11.08	7.56	3.84	5.31	1.62
120													12.75	13.01	8.25	4.52	5.79	1.91
130													13.82	15.09	8.94	5.24	6.27	2.21
140													14.88	17.31	9.63	6.01	6.75	2.54
150													15.94	19.67	10.32	6.83	7.24	2.88
160													17.01	22.17	11.00	7.69	7.72	3.25
170													18.07	24.81	11.69	8.61	8.20	3.64
180													19.13	27.58	12.38	9.57	8.69	4.04
190															13.07	10.58	9.17	4.47
200															13.76	11.63	9.65	4.91
225															15.48	14.47	10.86	6.11
250															17.20	17.58	12.07	7.43
275															18.92	20.98	13.27	8.86
300																	14.48	10.41
325																	15.69	12.07
350																	16.89	13.85
375																	18.10	15.73
400																	19.31	17.73
425																		
450																		
475																		
500																		
550																		
600																		

Note: Shaded areas of the chart indicate velocities over 5 feet per second (FPS). Use with caution.

CHARTS

Polyethylene (PE) SDR-Pressure Rated Tube

SIZES: 1/2" through 6"

FLOW: 1 – 600 GPM

PSI LOSS: Per 100' of tube (PSI/100 FT)

C = 140 (2306, 3206, 3306) SDR 7, 9, 11.5, 15

SIZE	1/2"		3/4"		1"		1 1/4"		1 1/2"		2"		2 1/2"		3"		4"		6"	
ID	0.622		0.824		1.049		1.380		1.610		2.067		2.469		3.068		4.026		6.065	
FLOW G. P. M.	Velocity FPS	psi Loss	Velocity FPS	psi Loss	Velocity FPS	psi Loss	Velocity FPS	psi Loss	Velocity FPS	psi Loss	Velocity FPS	psi Loss	Velocity FPS	psi Loss	Velocity FPS	psi Loss	Velocity FPS	psi Loss	Velocity FPS	psi Loss
1	1.05	0.49	0.60	0.12	0.37	0.04	0.21	0.01	0.15	0.00	0.09	0.00								
2	2.10	1.76	1.20	0.45	0.74	0.14	0.42	0.04	0.31	0.02	0.19	0.01								
3	3.16	3.73	1.80	0.95	1.11	0.29	0.64	0.08	0.47	0.04	0.28	0.01	0.20	0.00						
4	4.21	6.35	2.40	1.62	1.48	0.50	0.85	0.13	0.62	0.06	0.38	0.02	0.26	0.01						
5	5.27	9.60	3.00	2.44	1.85	0.76	1.07	0.20	0.78	0.09	0.47	0.03	0.33	0.01	0.21	0.00				
6	6.32	13.46	3.60	3.43	2.22	1.06	1.28	0.28	0.94	0.13	0.57	0.04	0.40	0.02	0.26	0.01				
7	7.38	17.91	4.20	4.56	2.59	1.41	1.49	0.37	1.10	0.18	0.66	0.05	0.46	0.02	0.30	0.01				
8	8.43	22.93	4.80	5.84	2.96	1.80	1.71	0.474	1.25	0.22	0.76	0.07	0.53	0.03	0.34	0.03				
9	9.49	28.52	5.40	7.26	3.33	2.24	1.92	0.59	1.41	0.28	0.85	0.08	0.60	0.03	0.39	0.01				
10	10.54	34.67	6.00	8.82	3.70	2.73	2.14	0.72	1.57	0.34	0.95	0.10	0.66	0.04	0.43	0.01				
11	11.60	41.36	6.00	10.53	4.07	3.25	2.35	0.86	1.73	0.40	1.05	0.12	0.73	0.05	0.47	0.02	0.27	0.00		
12	12.65	48.60	7.21	12.37	4.44	3.82	2.57	1.01	1.88	0.48	1.14	0.14	0.80	0.06	0.52	0.02	0.30	0.01		
14	14.76	64.65	8.41	16.46	5.19	5.08	2.99	1.34	2.20	0.63	1.33	0.19	0.93	0.08	0.60	0.03	0.35	0.01		
16	16.87	82.79	9.61	21.07	5.93	6.51	3.42	1.71	2.51	0.81	1.52	0.24	1.07	0.10	0.69	0.04	0.40	0.01		
18	18.89	102.97	10.81	26.21	6.67	8.10	3.85	2.13	2.83	1.01	1.71	0.30	1.20	0.13	0.78	0.04	0.45	0.01		
20			12.01	31.86	7.41	9.84	4.28	2.59	3.14	1.22	1.90	0.36	1.33	0.15	0.86	0.05	0.50	0.01		
22			13.21	38.01	8.15	11.74	4.71	3.09	3.46	1.46	2.10	0.43	1.47	0.18	0.95	0.06	0.55	0.02		
24			14.42	44.65	8.89	13.79	5.14	3.63	3.77	1.72	2.29	0.51	1.60	0.21	1.04	0.07	0.60	0.02		
26			15.62	41.79	9.64	16.00	5.57	4.21	4.09	1.99	2.48	0.59	1.74	0.25	1.12	0.09	0.65	0.02		
28			16.82	59.41	10.38	18.35	5.99	4.83	4.40	2.28	2.67	0.68	1.87	0.29	1.21	0.10	0.70	0.03		
30			18.02	67.50	11.12	20.85	6.42	5.49	4.72	2.59	2.86	0.77	2.00	0.32	1.30	0.11	0.75	0.03	0.33	0.00
35					12.97	27.74	7.49	7.31	5.50	3.45	3.34	1.02	2.34	0.43	1.51	0.15	0.88	0.04	0.38	0.01
40					14.83	35.53	8.56	9.36	6.29	4.42	3.81	1.31	2.67	0.55	1.73	0.19	1.00	0.05	0.44	0.01
45					16.68	44.19	9.64	11.64	7.08	5.50	4.29	1.63	3.01	0.69	1.95	0.24	1.13	0.06	0.49	0.01
50					18.53	53.71	10.71	14.14	7.87	6.68	4.77	1.98	3.34	0.83	2.16	0.29	1.25	0.08	0.55	0.01
55					11.78	16.87	8.65	7.97	5.25	2.36	3.68	1.00	2.38	0.35	1.38	0.09	0.61	0.01		
60					12.85	19.82	9.44	9.36	5.72	2.78	4.01	1.17	2.60	0.41	1.51	0.11	0.66	0.01		
65					13.92	22.99	10.23	10.86	6.20	3.22	4.35	1.36	2.81	0.47	1.63	0.13	0.72	0.02		
70					14.99	26.37	11.01	12.46	6.68	3.69	4.68	1.56	3.03	0.54	1.76	0.14	0.77	0.02		
75					16.06	29.97	11.80	14.16	7.16	4.20	5.01	1.77	3.25	0.61	1.88	0.16	0.83	0.02		
80					17.13	33.77	12.59	15.95	7.63	4.73	5.35	1.99	3.46	0.69	2.01	0.18	0.88	0.03		
85					18.21	37.79	13.37	17.85	8.11	5.29	5.68	2.23	3.68	0.77	2.13	0.21	0.94	0.03		
90					19.28	42.01	14.16	19.84	8.59	5.88	6.02	2.48	3.90	0.86	2.26	0.23	0.99	0.03		
95							14.95	21.93	9.07	6.50	6.35	2.74	4.11	0.95	2.39	0.25	1.05	0.03		
100									15.74	24.12	9.54	7.15	6.69	3.01	4.33	1.05	2.51	0.28	1.10	0.04
110									17.31	28.77	10.50	8.53	7.36	3.59	4.76	1.25	2.76	0.33	1.22	0.05
120									18.88	33.80	11.45	10.02	8.03	4.22	5.20	1.47	3.02	0.39	1.33	0.05
130											12.41	11.62	8.70	4.90	5.63	1.70	3.27	0.45	1.44	0.06
140											13.36	13.33	9.37	5.62	6.06	1.95	3.52	0.52	1.55	0.07
150											14.32	15.15	10.03	6.38	6.50	2.22	3.77	0.59	1.66	0.08
160											15.27	17.08	10.70	7.19	6.93	2.50	4.02	0.67	1.77	0.09
170											16.23	19.11	11.37	8.05	7.36	2.80	4.27	0.75	1.88	0.10
180											17.18	21.24	12.04	8.95	7.08	3.11	4.53	0.83	1.99	0.11
190											18.14	23.48	12.71	9.89	8.23	3.44	4.78	0.92	2.10	0.12
200											19.09	25.81	13.38	10.87	8.66	3.78	5.03	1.01	2.21	0.14
225													15.05	13.52	9.75	4.70	5.66	1.25	2.49	0.17
250													16.73	16.44	10.83	5.71	6.29	1.52	2.77	0.21
275													18.40	19.61	11.92	6.82	6.92	1.82	3.05	0.25
300															13.00	8.01	7.55	2.13	3.32	0.29
325															14.08	9.29	8.18	2.48	3.60	0.34
350															15.17	10.65	8.81	2.84	3.88	0.39
375															16.25	12.10	9.43	3.23	4.15	0.44
400															17.33	13.64	10.06	3.64	4.43	0.50
425															18.42	15.26	10.69	4.07	4.71	0.55
450															19.50	16.97	11.32	4.52	4.99	0.62
475																	11.95	5.00	5.26	0.68
500																	12.58	5.50	5.54	0.75
550																	13.84	6.56	6.10	0.89
600																	15.10	7.70	6.65	1.05

Note: ■ Shaded areas of the chart indicate velocities over 5 feet per second (FPS). Use with caution.

CHARTS

Schedule 40 Standard Steel Pipe

SIZES: 1/2" through 6"

FLOW: 1 – 600 GPM

PSI LOSS: Per 100' of pipe (PSI/100 FT)

C = 100

SIZE	1/2"		3/4"		1"		1 1/4"		1 1/2"		2"		2 1/2"		3"		4"		6"	
OD	0.840		1.050		1.315		1.660		1.900		2.375		2.875		3.500		4.500		6.625	
ID	0.622		0.824		1.049		1.380		1.610		2.067		2.469		3.068		4.026		6.065	
WALL THK.	0.109		0.113		0.133		0.140		0.145		0.154		0.203		0.216		0.237		0.280	
FLOW G. P. M.	Velocity FPS	psi Loss	Velocity FPS	psi Loss	Velocity FPS	psi Loss	Velocity FPS	psi Loss	Velocity FPS	psi Loss	Velocity FPS	psi Loss	Velocity FPS	psi Loss	Velocity FPS	psi Loss	Velocity FPS	psi Loss	Velocity FPS	psi Loss
1	1.05	0.91	0.60	0.23	0.37	0.07	0.21	0.02	0.15	0.01	0.09	0.00								
2	2.10	3.28	1.20	0.84	0.74	0.26	0.42	0.07	0.31	0.03	0.19	0.01	0.13	0.00						
3	3.16	6.95	1.80	1.77	1.11	0.55	0.64	0.14	0.47	0.07	0.28	0.02	0.20	0.01	0.13	0.00				
4	4.21	11.85	2.40	3.02	1.48	0.93	0.85	0.25	0.62	0.12	0.38	0.03	0.26	0.01	0.17	0.01				
5	5.27	17.91	3.00	4.56	1.85	1.41	1.07	0.37	0.78	0.18	0.47	0.05	0.33	0.02	0.21	0.01				
6	6.32	25.10	3.60	6.39	2.22	1.97	1.28	0.52	0.94	0.25	0.57	0.07	0.40	0.03	0.26	0.01				
7	7.38	33.40	4.20	8.50	2.59	2.63	1.49	0.69	1.10	0.33	0.66	0.10	0.46	0.04	0.30	0.01				
8	8.43	42.77	4.80	10.89	2.96	3.36	1.71	0.89	1.25	0.42	0.76	0.12	0.53	0.05	0.34	0.02	0.20	0.00		
9	9.49	53.19	5.40	13.54	3.33	4.18	1.92	1.10	1.41	0.52	0.85	0.15	0.60	0.06	0.39	0.02	0.22	0.01		
10	10.54	64.65	6.00	16.46	3.70	5.08	2.14	1.34	1.57	0.63	0.95	0.19	0.66	0.08	0.43	0.03	0.25	0.01		
11	11.60	77.13	6.60	19.63	4.07	6.07	2.35	1.60	1.73	0.75	1.05	0.22	0.73	0.09	0.47	0.03	0.27	0.01		
12	12.65	90.62	7.21	23.07	4.44	7.13	2.57	1.88	1.88	0.89	1.14	0.26	0.80	0.11	0.52	0.04	0.30	0.01		
14	14.76	20.56	8.41	30.69	5.19	9.48	2.99	2.50	2.20	1.18	1.33	0.35	0.93	0.15	0.60	0.05	0.35	0.01		
16	16.87	54.39	9.61	39.30	5.93	12.14	3.42	3.20	2.51	1.51	1.52	0.45	1.07	0.19	0.69	0.07	0.40	0.02		
18	18.89	92.02	10.81	48.88	6.67	15.10	3.85	3.98	2.83	1.88	1.71	0.56	1.20	0.23	0.78	0.08	0.45	0.02		
20			12.01	59.41	7.41	18.35	4.28	4.83	3.14	2.28	1.90	0.68	1.33	0.29	0.86	0.10	0.50	0.03		
22			13.21	70.88	8.15	21.90	4.71	5.77	3.46	2.72	2.10	0.81	1.47	0.34	0.95	0.12	0.55	0.03	0.24	0.00
24			14.42	83.27	8.89	25.72	5.14	6.77	3.77	3.20	2.29	0.95	1.60	0.40	1.04	0.14	0.60	0.04	0.26	0.01
26			15.62	96.57	9.64	29.83	5.57	7.86	4.09	3.71	2.48	1.10	1.74	0.46	1.12	0.16	0.65	0.04	0.28	0.01
28			16.82	110.8	10.38	34.22	5.99	9.01	4.40	4.26	2.67	1.26	1.87	0.53	1.21	0.18	0.70	0.05	0.31	0.01
30			18.02	125.9	11.12	38.89	6.42	10.24	4.72	4.84	2.86	1.43	2.00	0.60	1.30	0.21	0.75	0.06	0.33	0.01
35					12.97	51.74	7.49	13.62	5.50	6.44	3.34	1.91	2.34	0.80	1.51	0.28	0.88	0.07	0.38	0.01
40					14.83	66.25	8.56	17.45	6.29	8.24	3.81	2.44	2.67	1.03	1.73	0.36	1.00	0.10	0.44	0.01
45					16.68	82.40	9.64	21.70	7.08	10.25	4.29	3.04	3.01	1.28	1.95	0.44	1.13	0.12	0.49	0.02
50					18.53	100.2	10.71	26.37	7.87	12.46	4.77	3.69	3.34	1.56	2.16	0.54	1.25	0.14	0.55	0.02
55					11.78	31.47	8.65	14.86	5.25	4.41	3.68	1.86	2.38	0.65	1.38	0.17	0.61	0.02		
60					12.85	36.97	9.44	17.46	5.72	5.18	4.01	2.18	2.60	0.76	1.51	0.20	0.66	0.03		
65					13.92	42.88	10.23	20.25	6.20	6.00	4.35	2.53	2.81	0.88	1.63	0.23	0.72	0.03		
70					14.99	49.18	11.01	23.23	6.68	6.89	4.68	2.90	3.03	1.01	1.76	0.27	0.77	0.04		
75					16.06	55.89	11.80	26.40	7.16	7.83	5.01	3.30	3.25	1.15	1.88	0.31	0.83	0.04		
80					17.13	62.98	12.59	29.75	7.63	8.82	5.35	3.72	3.46	1.29	2.01	0.34	0.88	0.05		
85					18.21	70.47	13.37	33.29	8.11	9.87	5.68	4.16	3.68	1.44	2.13	0.39	0.94	0.05		
90					19.28	78.33	14.16	37.00	8.59	10.97	6.02	4.62	3.90	1.61	2.26	0.43	0.99	0.06		
95							14.95	40.90	9.07	12.13	6.35	5.11	4.11	1.78	2.39	0.47	1.05	0.06		
100							15.74	44.97	9.54	13.33	6.69	5.62	4.33	1.95	2.51	0.52	1.10	0.07		
110							17.31	53.66	10.50	15.91	7.36	6.7	4.76	2.33	2.76	0.62	1.22	0.08		
120							18.88	63.04	11.45	18.69	8.03	7.87	5.20	2.74	3.02	0.73	1.33	0.10		
130									12.41	21.68	8.70	9.13	5.63	3.17	3.27	0.85	1.44	0.12		
140									13.36	24.87	9.37	10.47	6.06	3.64	3.52	0.97	1.55	0.13		
150									14.32	28.26	10.03	11.90	6.50	4.14	3.77	1.10	1.66	0.15		
160									15.27	31.84	10.70	13.41	6.93	4.66	4.02	1.24	1.77	0.17		
170									16.23	35.63	11.37	15.01	7.36	5.22	4.27	1.39	1.88	0.19		
180									17.18	39.61	12.04	16.68	7.80	5.80	4.53	1.55	1.99	0.21		
190									18.14	43.78	12.71	18.44	8.23	6.41	4.78	1.71	2.10	0.23		
200									19.09	48.14	13.38	20.28	8.66	7.05	5.03	1.88	2.21	0.26		
225											15.08	25.22	9.75	8.76	5.66	2.34	2.49	0.32		
250											16.73	30.65	10.83	10.65	6.29	2.84	2.77	0.39		
275											18.40	36.57	11.92	12.71	6.92	3.39	3.05	0.46		
300															13.00	14.93	7.55	3.98	3.32	0.54
325															14.08	17.32	8.18	4.62	3.60	0.63
350															15.17	19.87	8.81	5.30	3.88	0.72
375															16.25	22.57	9.43	6.02	4.15	0.82
400															17.33	25.44	10.06	6.78	4.43	0.92
425															18.42	28.46	10.69	7.59	4.71	1.03
450															19.50	31.64	11.32	8.43	4.99	1.15
475																11.95	9.32	5.26	1.27	
500																12.58	10.25	5.54	1.40	
550																13.84	12.23	6.10	1.67	
600																15.10	14.37	6.65	1.96	

Note: Shaded areas of the chart indicate velocities over 5 feet per second (FPS). Use with caution.

WARRANTY

Limited Product Warranty

All K-Rain gear drive rotors carry a five year **“Limited Warranty”** from the date of purchase. All other K-Rain products carry a two year **“Limited Warranty”** from the date of purchase unless otherwise stated. During this period K-Rain will repair or replace (at K-Rain’s option) the product or any part if the product is found to be defective as to workmanship or material.

This warranty does not extend to damage to a K-Rain product resulting from misuse, neglect or abuse, normal wear and tear, or accident, to exterior appearance or color or due to improper installation. Various products may carry a longer warranty time period; check individual product specification sheets for warranty period.

This warranty extends only to an original user of a K-Rain product.

IN NO EVENT SHALL K-RAIN BE LIABLE FOR INCIDENTAL OR CONSEQUENTIAL DAMAGES. ALL IMPLIED WARRANTIES ARE LIMITED IN DURATION TO TWO YEARS FOLLOWING DATE OF PURCHASE UNLESS INDICATED OTHERWISE.

Some U.S. states do not permit the exclusion or limitation of incidental or consequential damages or of implied warranties. Therefore, the above exclusions or limitations may not apply to you. If a defect arises in a K-Rain product within the warranty period, you should promptly contact your K-Rain installer, distributor or K-RAIN MANUFACTURING CORPORATION.

This warranty gives you specific legal rights, and you may also have other rights which vary from state to state. If you have any questions concerning the warranty or its application, please contact K-Rain:

K-Rain Manufacturing Corp.

1640 Australian Avenue
Riviera Beach, FL 33404 USA
+1 561 844-1002
FAX: +1 561 842-9493
1.800.735.7246 | www.krain.com

NOTES



K-Rain Manufacturing Corp.
1640 Australian Avenue
Riviera Beach, FL 33404 USA
561.844.1002
FAX: 561.842.9493
1.800.735.7246 | www.krain.com

© K-Rain Manufacturing Corporation
AN ISO 9001:2008 CERTIFIED COMPANY